

S P A C E

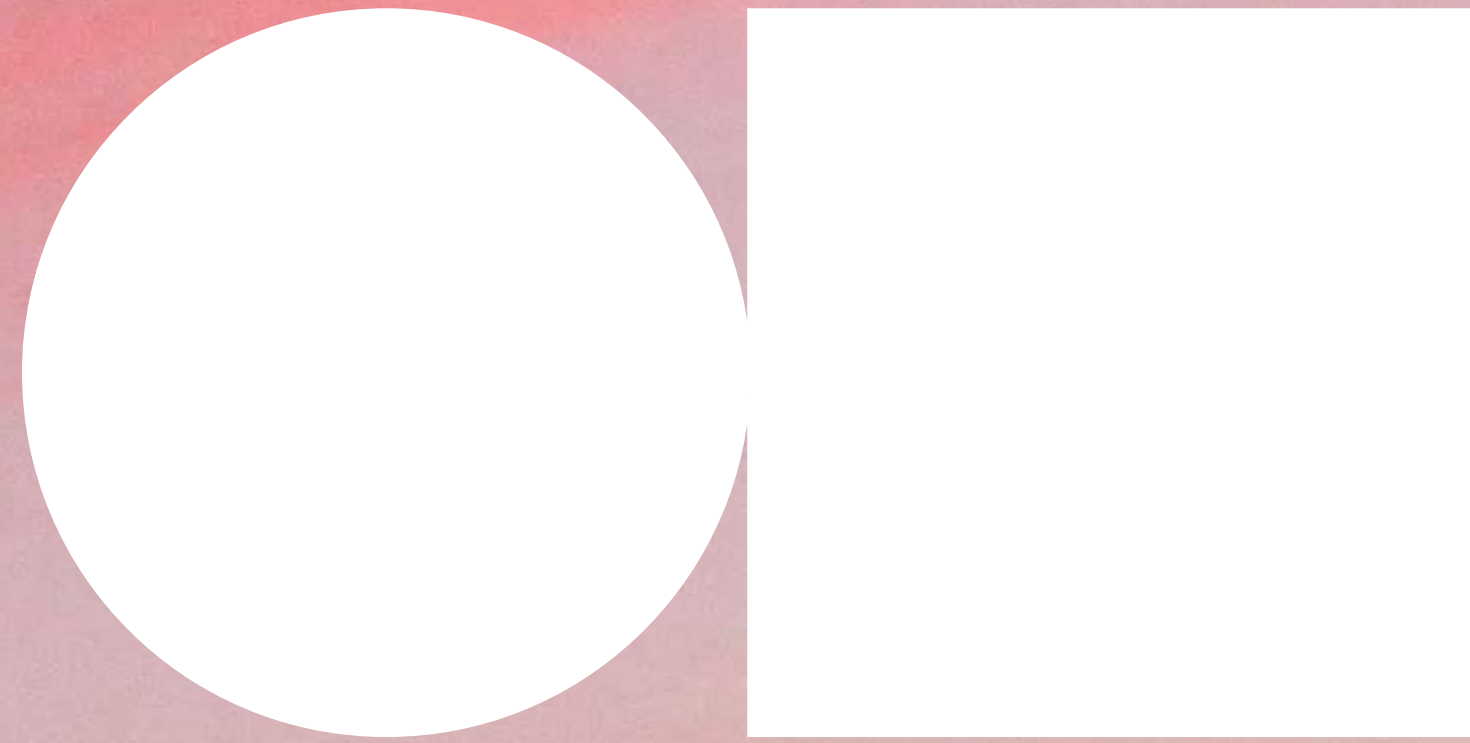

H O U S E

SEE BEYOND



SPACE HOUSE IS ONE OF LONDON'S MOST REMARKABLE MID-CENTURY GRADE II LISTED BUILDINGS. ITS SENSITIVE AND SUSTAINABLE RESTORATION AND MODERNISATION HAS REVEALED A PROGRESSIVE AND UNIQUE ENVIRONMENT IN WHICH AMBITIOUS BUSINESSES CAN THRIVE.

230,100 sq ft smart, adaptable net zero carbon workspaces, filled with character, personality, flooded by natural daylight and rarely seen 360° views of London.

27,700 sq ft of lifestyle spaces, a new one-acre public piazza and a curated learning, wellness, and cultural programme, all designed to put people first.

A new type of workplace, providing flexibility, choice, and a genuine sense of community, all located within the culturally rich and lively neighbourhood of Covent Garden in the heart of central London.

A BEACON

FOR CHANGE

Space House is a progressive cultural icon, a fearless challenger of preconceptions and an inspiring space for people who think differently.

| | | | | |
|--|--|--|--|--|
| | | | | |
| | | | | |



230,100 SQ FT OF WORKSPACE

Flexible, adaptable light-filled spaces with 360° views of London. A modernised, iconic Grade II listed building with unique and characterful exposed architectural features. Choice of four different workspace typologies.

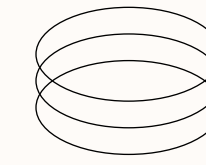
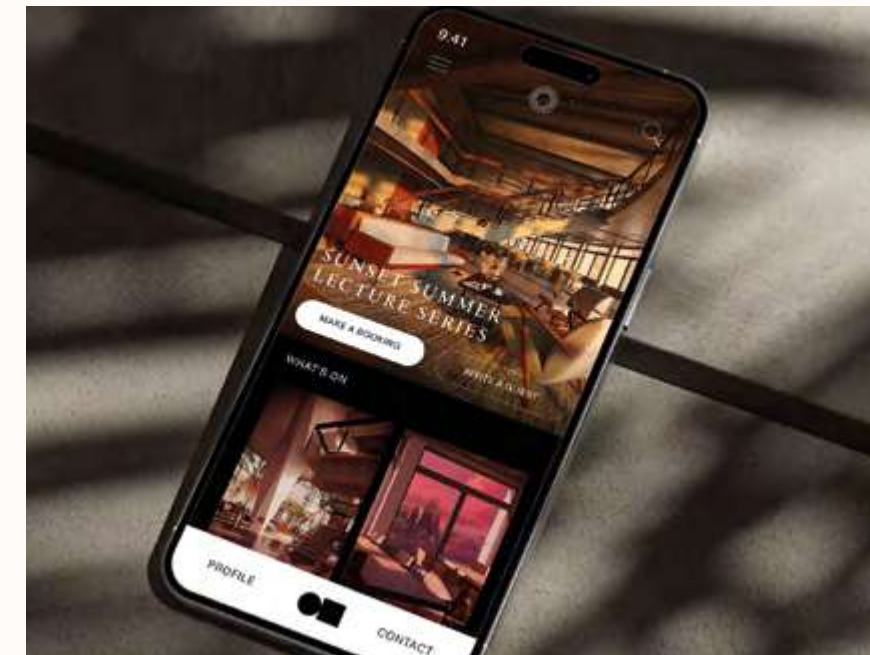

FUTURE-READY TECHNOLOGY

The fully-electric smart building infrastructure and the Space House app integrate to provide a fully connected seamless personal experience. Continual analysis of energy consumption, air and water quality, and thermal comfort levels delivers a healthy and productive working environment.

WIREScore PLATINUM

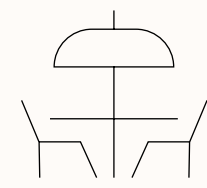

27,700 SQ FT OF LIFESTYLE SPACES

A lifestyle building, designed for mental and physical wellbeing and social connection. Six lifestyle spaces: Filling Station restaurant, Lounge, Clubhouse + Terrace, Cycle Club, Space Studios event hub and a one-acre public piazza with seasonal food trucks.

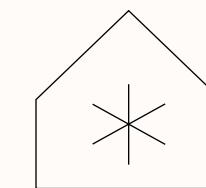

A SUSTAINABILITY EXEMPLAR

Sensitively redeveloped for a digital, more carbon-conscious age, setting a new standard for the redevelopment of historic buildings. Net zero carbon in operation to reduce carbon footprint and reduce occupier costs.

BREEAM OUTSTANDING
NABERS 4.5*
EPC A

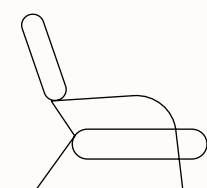

MEMBERS' CLUB-STYLE PHILOSOPHY

Contemporary lobby experience, attentive concierge team, a carefully curated programme of wellness and cultural experiences, a learning menu and social gatherings. To surprise and delight, and enrich the everyday.

FITWELL 2*

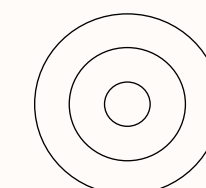

WORLD-FAMOUS CULTURE AND BUSINESS DISTRICT

Covent Garden, the heart of London. Renowned for its rich culture and creative spirit, famous cultural landmarks, and some of the world's finest retailers, restaurants, bars and hotels. Home to visionary companies and thinkers brilliantly shaping the future.



“SPACE HOUSE IS ONE OF THE MOST IMPORTANT REDEVELOPMENT PROJECTS OF OUR TIME.”

HISTORIC ENGLAND

The regeneration of Space House in Covent Garden pushes the boundaries of responsible redevelopment. It is an authentic, considered approach to breathe new life into a sixty-year-old Grade II listed building, helping to protect the future of London’s historic buildings.

The result is a progressive, high-specification work and lifestyle space, and one of the only BREEAM Outstanding listed workplaces in the UK, thanks to a number of engineering innovations unique to this building.

SPACE



HOUSE

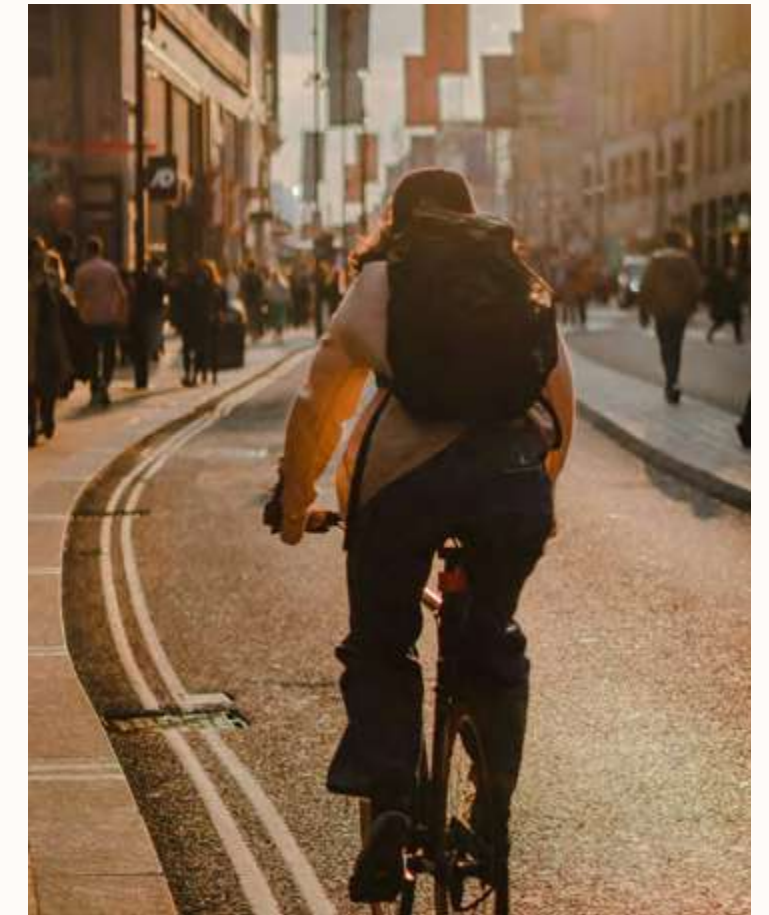

A

LIFESTYLE

CHOICE



Space House is designed to put people first. It responds to the modern workplace agenda, where flexibility, lifestyle, wellness, and amenities stimulate the work environment. Conceived to feel more like a hospitality

environment than a traditional office campus, everything has been designed and detailed to help your teams get the most out of their days, making the commute more than worthwhile.

BEYOND



Space House benefits from 28,000 sq ft of contemporary lifestyle spaces akin to those found in a modern members' club. A concierge, learning menu, wellness activities and cultural events programme are available exclusively for occupiers and their guests.

THE OFFICE



PUBLIC PIAZZA



ACTIVE LIFESTYLE FACILITIES



THE LOUNGE



THE FILLING STATION



SPACE STUDIOS



THE CLUBHOUSE + TERRACE

SIX LIFESTYLE SPACES

Imagine a reality where the more you go to work, the healthier, happier and more fulfilled you become. Thoughtful lifestyle spaces have been designed to embrace community and foster a

sense of belonging; enlivening and enhancing the every day experience of everyone who works from Space House.



PUBLIC PIAZZA



The redevelopment has created a new one-acre public space, complete with trees, soft landscaping, and benches.

Vintage food trucks offer a rotating mix of barista coffees and the best street cuisine, creating a lively atmosphere and sense of place.



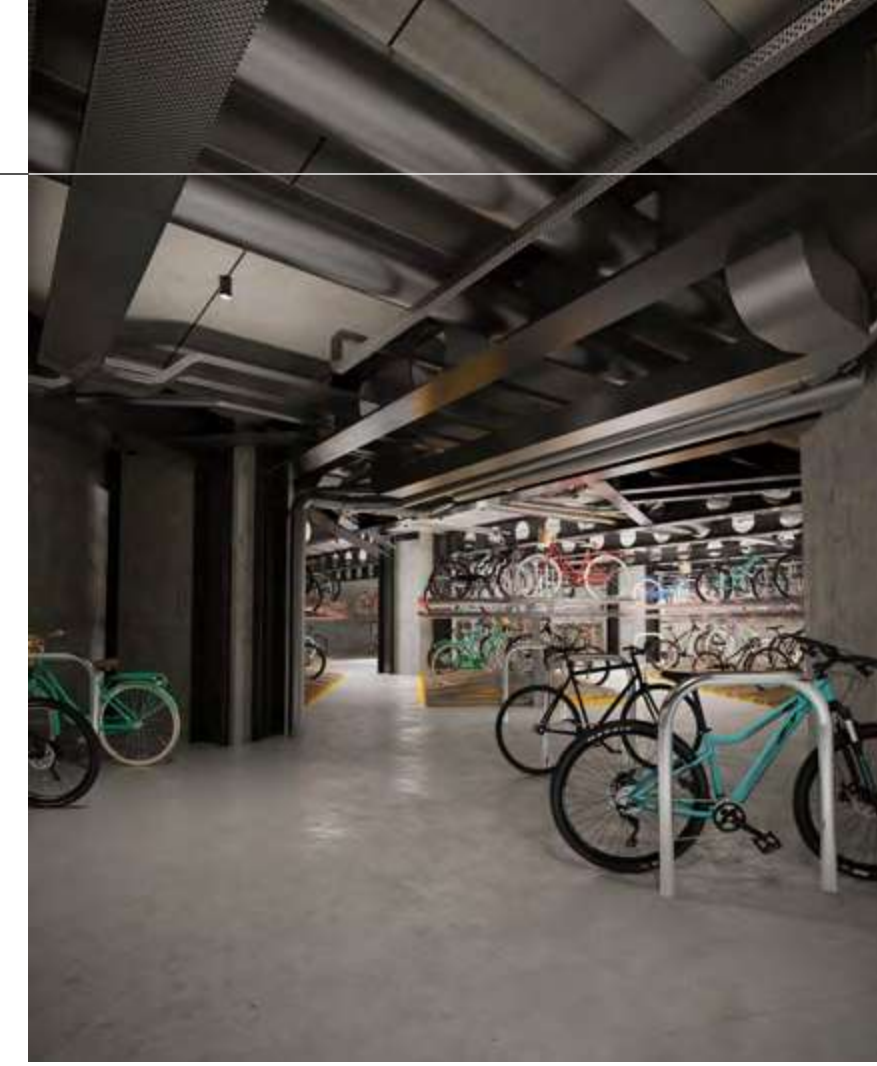

ACTIVE LIFESTYLE FACILITIES



Cycle straight in off the street, down the ramp and into the bike park. Grab a quick shower then straight up in the lift to your office. Space House has repurposed its original underground car park to provide exceptional spaces for active lifestyles and green commuting, including 550 bike spaces – the largest pro rata provision in central London, and 65 individual shower rooms.



LOUNGE



The Lounge serves as a fun and uplifting day-through-night space at the base of the Tower. A great place for an informal meeting, or touchdown workspace during the day, and by night, the Lounge will play host to a resident DJ and inspiring talks and events.





THE FILLING STATION



Originally a petrol station, the now strikingly open and airy restaurant at the base of the Tower is the perfect place to catch up with friends, clients and colleagues.

Enjoy breakfast, lunch, dinner or drinks beneath the building's stunning Y-columns and fluted canopy or al fresco in the public piazza.



SPACE STUDIOS



The original car park has been reimagined as a 16,000 sq ft event space for people to connect, learn, entertain, and be inspired.





THE CLUBHOUSE + TERRACE

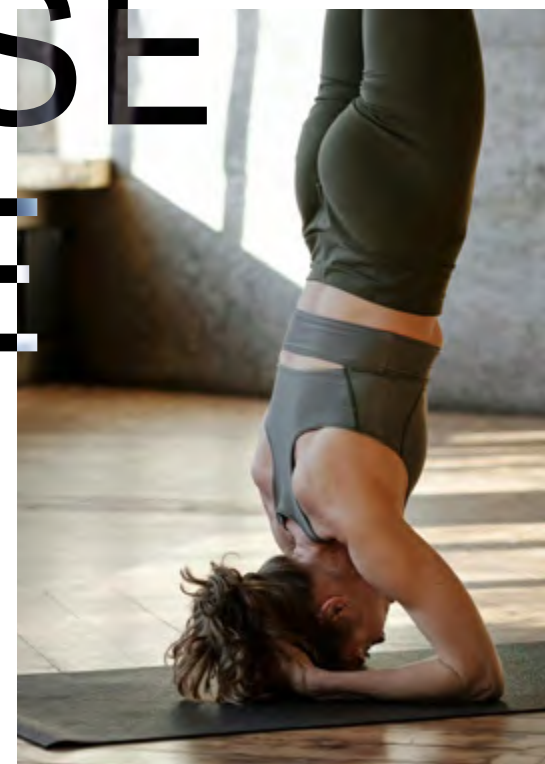

At the top of the Block is the Clubhouse and Terrace. Enjoy early morning yoga on the terrace, breakfast, light snacks and drinks throughout the day. The space is bookable in the evenings for private events.





A WORKSPACE



REVOLUTION

A building designed to foster collaboration, each floor of Space House offers complete freedom and flexibility, creating an ideal working environment for your team.

The egalitarian workspaces feature long sightlines, offering high levels of visual connectivity to support seamless collaborative working. The circular, column-free floorplates of the Tower ensure the space is flooded with natural light.

SKY LOFT

LEVELS 13-17

Panoramic rooftop terrace
10,300 sq ft floor plates
Total: 46,000 sq ft

THE TOWER

LEVELS 1-12

10,300 sq ft floor plates
Total: 125,400 sq ft

GROUND FLOOR

Entrance lobby for The
Tower on Kemble Street



FOUR WAYS TO OCCUPY SPACE HOUSE

230,100 SQ FT WORKSPACE

THE BLOCK

LEVELS G-7

8,000 sq ft floor plates
Total: 58,700 sq ft

HYBRID

LEVELS 1-3

19,300 sq ft floor plates
1,340 sq ft terrace
Total: 56,700 sq ft

GROUND FLOOR

Entrance lobby for The
Block on Keeley Street

THE ESTATE

The one-acre island site features a beautifully landscaped public realm by Gustafson, Porter & Bowman.

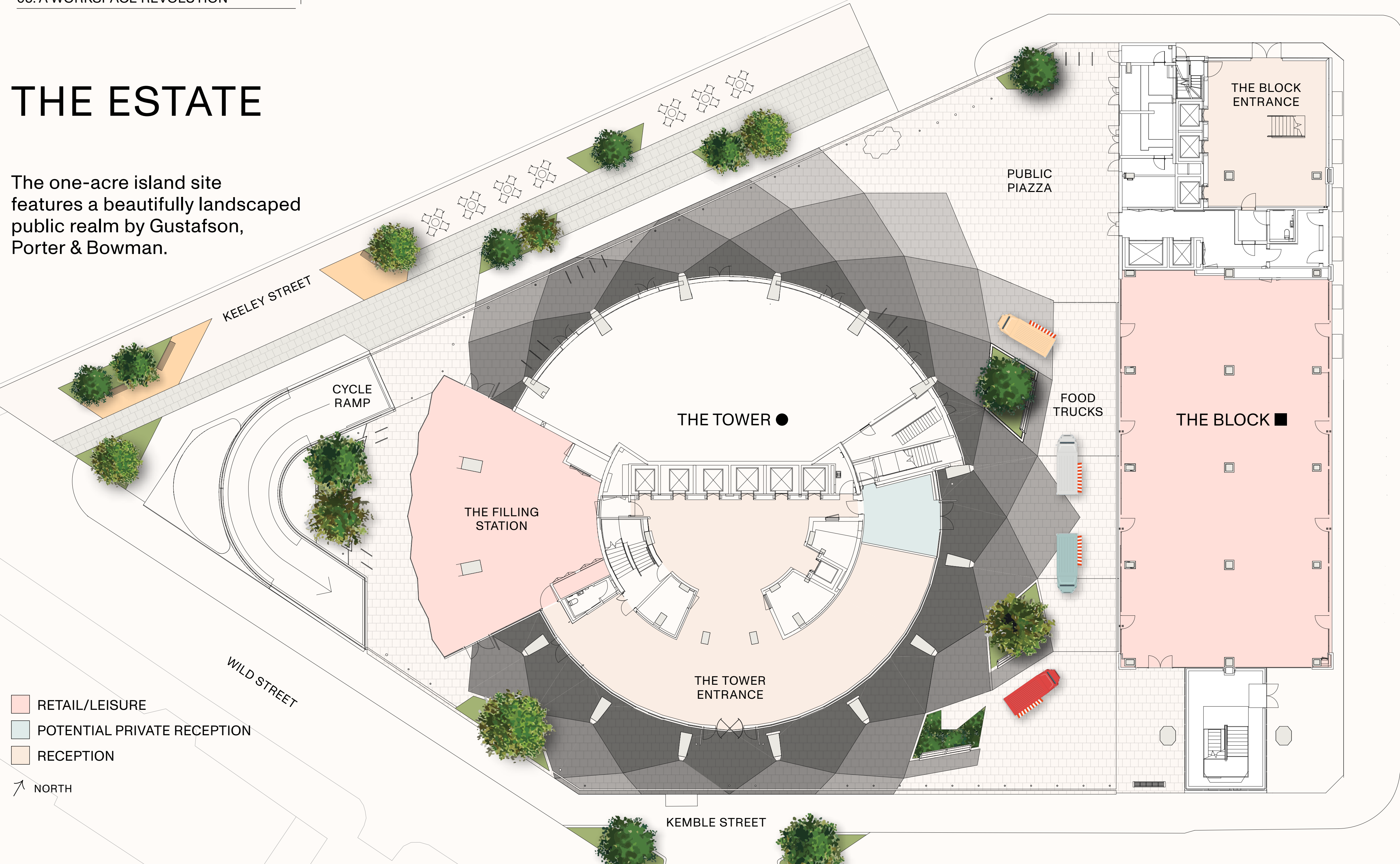

- RETAIL/LEISURE
- POTENTIAL PRIVATE RECEPTION
- RECEPTION

NORTH



A STATEMENT ARRIVAL



The iconic brutalist architecture of Space House provides a striking and unique arrival experience.





THE BLOCK ■

The Block's entrance lobby also celebrates the mid-century modern aesthetic and includes a replica of the original staircase, which has been carefully restored in the southern lobby.



THE TOWER ●

The sensitive restoration of Space House sees the mid-century modern aesthetic continue into the lobby. Beautiful terrazzo flooring and exposed structural columns are softened by warm fluted timber panels enveloping the main circular core and lift lobby.



↑
THE TOWER
South-facing entrance lobby to the workspace.



←
Floor-to-ceiling windows
ensure the workspaces are
flooded with natural light.





↑ Panoramic roof terrace on the 17th floor.

Panoramic views from 17th floor roof terrace.





↑
THE BLOCK

Typical workspace of 8,000 sq ft with full height windows on both sides.



↑
HYBRID
Workspaces on levels 1, 2 and 3 provide 20,000 sq ft floorplates. This space connects the Tower and the Block and benefits from shallow terraces on levels 1 and 2 and a 1,340 sq ft terrace on level 3.

SPACE TO



Space House has been designed to give you the physical and mental space to roam. Open floor planning on every level can be customised to fit your working habits and culture, creating a relaxed atmosphere for quiet contemplation, chance encounters and inspired collaboration.

ADAPT
BREATHE
CREATE
CONNECT
COLLABORATE
EVOLVE
GROW
INNOVATE
INSPIRE
IMAGINE
PLAY
THRIVE
SUCCEED

SCHEDULE OF AREAS

THE TOWER ●

| | | SQ FT |
|----|--------------------|--------|
| 17 | SKY LOFT + TERRACE | 4,800 |
| 16 | SKY LOFT | 10,300 |
| 15 | SKY LOFT | 10,300 |
| 14 | SKY LOFT | 10,300 |
| 13 | SKY LOFT | 10,300 |
| 12 | WORKSPACE | 10,300 |
| 11 | WORKSPACE | 10,300 |
| 10 | WORKSPACE | 10,300 |
| 9 | WORKSPACE | 10,300 |
| 8 | WORKSPACE | 10,300 |
| 7 | WORKSPACE | 10,300 |
| 6 | WORKSPACE | 10,300 |
| 5 | WORKSPACE | 10,300 |
| 4 | WORKSPACE | 10,300 |
| 3 | WORKSPACE | 10,300 |
| 2 | WORKSPACE | 11,300 |
| 1 | WORKSPACE | 11,100 |
| G | FILLING STATION | 2,200 |

HYBRID ●■

| | | | | | |
|-----|----------------------|---------------|--------|-----------|-------|
| LG1 | ACTIVE LIFESTYLE HUB | SPACE STUDIOS | 5,500 | ANCILLARY | 2,900 |
| LG2 | ACTIVE LIFESTYLE HUB | SPACE STUDIOS | 13,600 | | |

THE BLOCK ■

| | | SQ FT |
|---|---------------------|-------|
| 8 | CLUBHOUSE + TERRACE | 7,300 |
| 7 | WORKSPACE | 8,100 |
| 6 | WORKSPACE | 8,100 |
| 5 | WORKSPACE | 8,100 |
| 4 | WORKSPACE | 8,100 |
| 3 | WORKSPACE | 8,000 |
| 2 | WORKSPACE | 8,000 |
| 1 | WORKSPACE | 8,000 |
| G | WORKSPACE / RETAIL | 5,000 |

| TOTAL SQ |
|----------|
| 18,300 |
| 19,300 |
| 19,100 |

| | |
|--|------------------|
| TOTAL SKY LOFT WORKSPACE (LEVELS 13-17) | 46,000 SQ FT |
| TOTAL TOWER WORKSPACE (LEVELS 1-12) | 125,400 SQ FT |
| TOTAL BLOCK WORKSPACE (LEVELS G-7) | 61,400 SQ FT |
| TOTAL HYBRID WORKSPACE (LEVELS 1-3) | 56,700 SQ FT |
| TOTAL WORKSPACE (NIA) | 230,100 SQ FT |

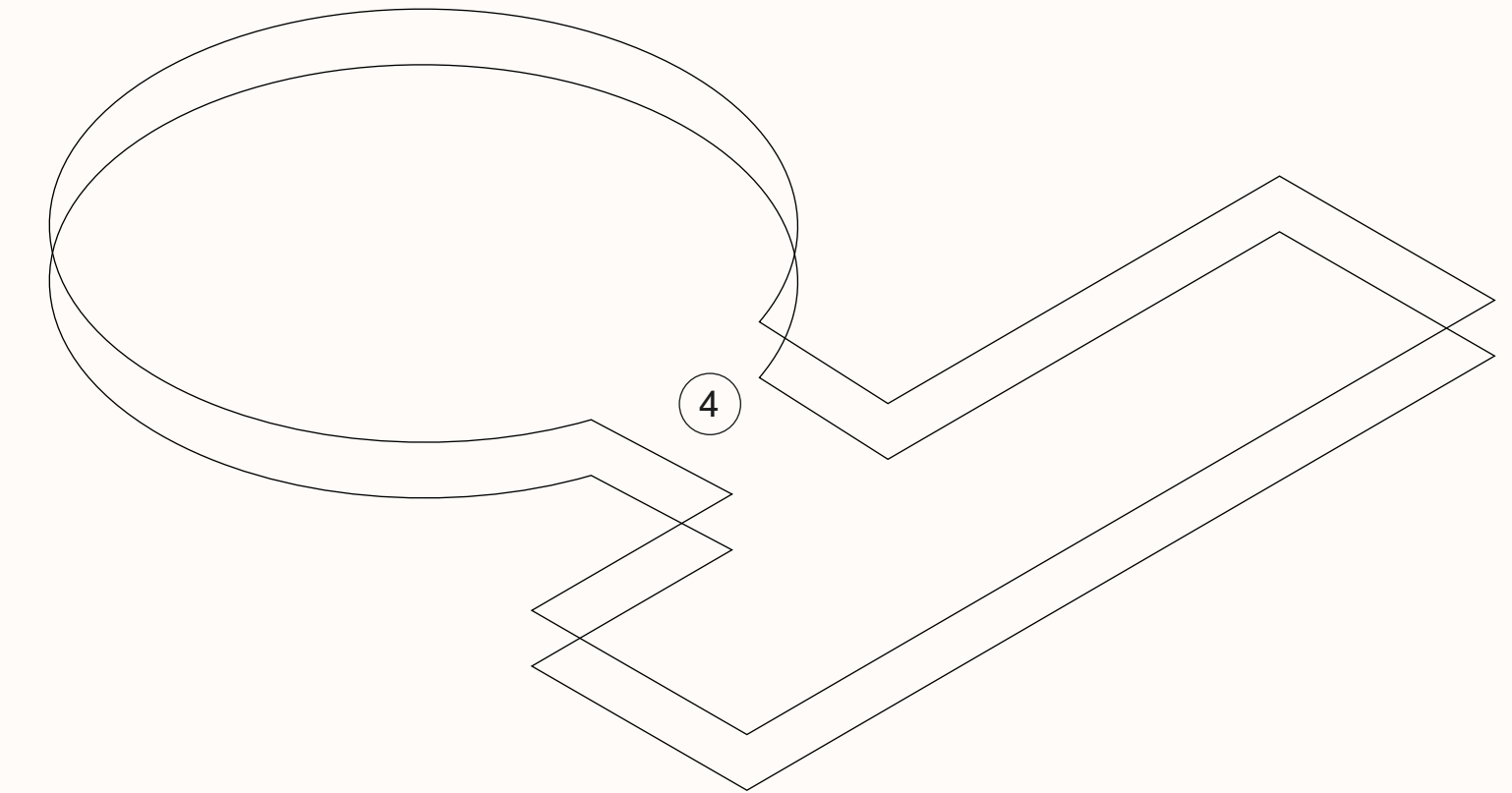
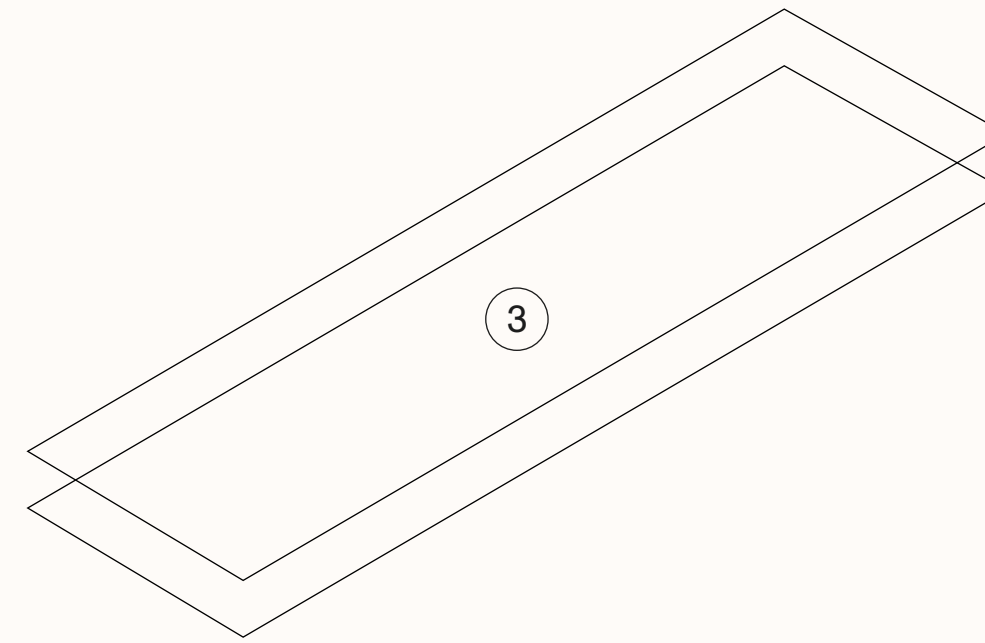
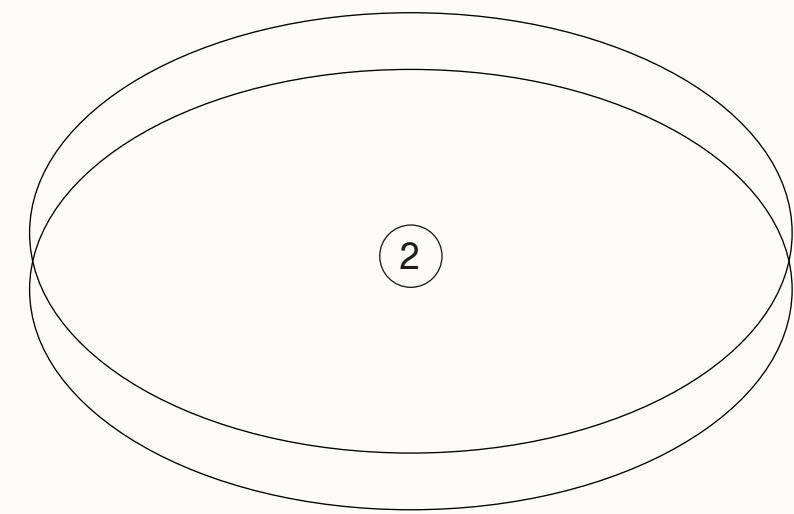
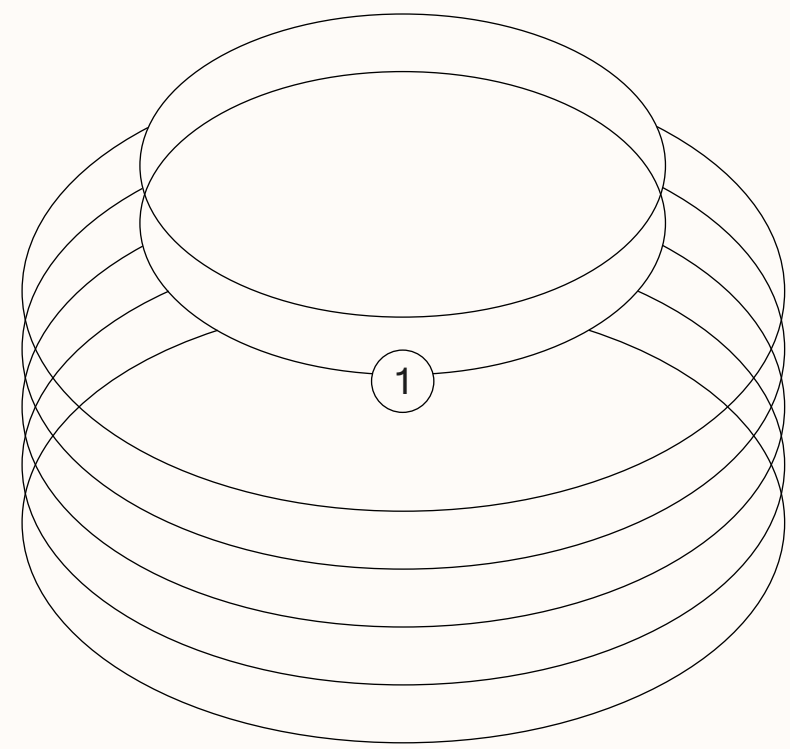

FLEXIBILITY TO WORK YOUR WAY

① SKY LOFT ☀️

LEVELS 13-17
 Panoramic rooftop terrace
 10,300 sq ft floor plates
 Total: 46,000 sq ft

② THE TOWER ●

LEVELS 1-12
 10,300 sq ft floor plates
 Total: 125,400 sq ft

③ THE BLOCK ■

LEVELS G-7
 8,000 sq ft floor plates
 Clubhouse and rooftop terrace
 Total: 61,400 sq ft

④ HYBRID ●■

LEVELS 1-3
 19,300 sq ft floor plates
 1,340 sq ft terrace
 Total: 56,700 sq ft

Space House gives you the freedom to choose how and where you work. From the inspiring heights of the Tower to the urban vibrancy of the Block, the space can be tailored to your work style, culture and preferences.

LEVEL 02

HYBRID 

WORKSPACE

19,300 sq ft

-  TERRACE
-  LIFTS
-  WORKSPACE
-  LIFT LOBBY
-  CORE

 NORTH

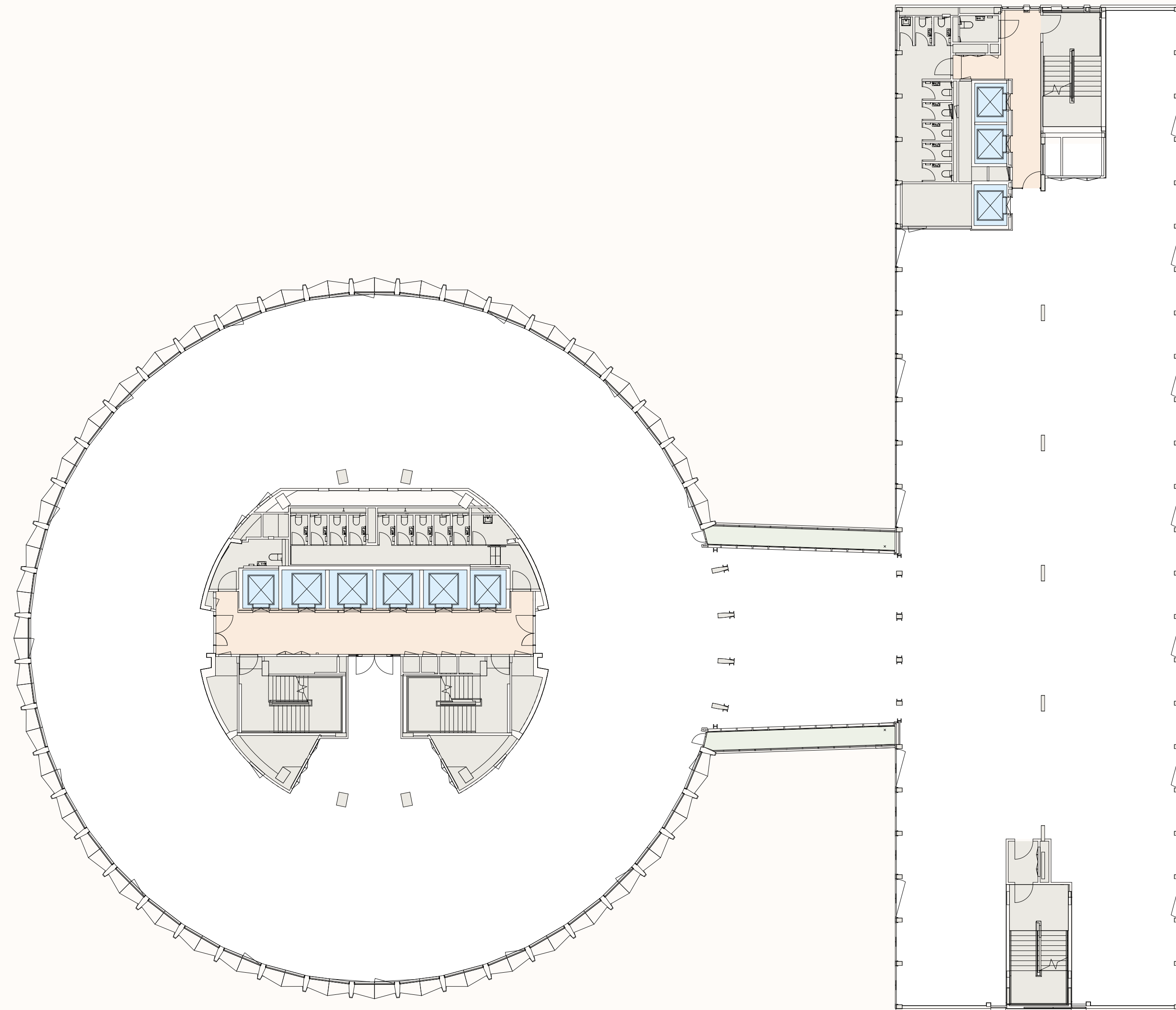

LEVEL 08

THE TOWER ●

WORKSPACE

10,300 sq ft

THE BLOCK ■

CLUBHOUSE TERRACE

2,290 sq ft 5,064 sq ft

- TERRACE
- TERRACE (AT LEVEL 03)
- CLUBHOUSE
- LIFTS
- WORKSPACE
- LIFT LOBBY
- CORE

↗ NORTH

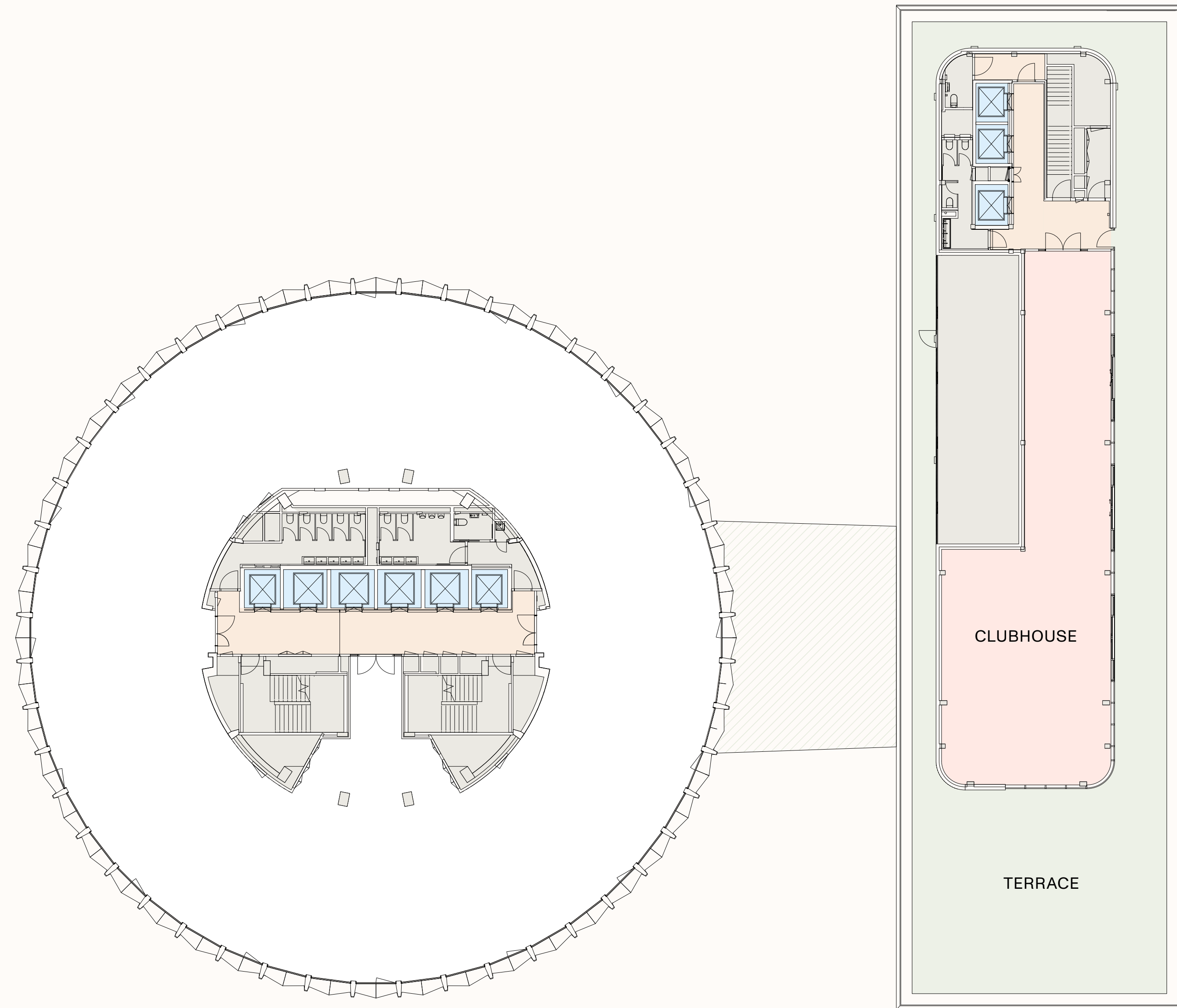





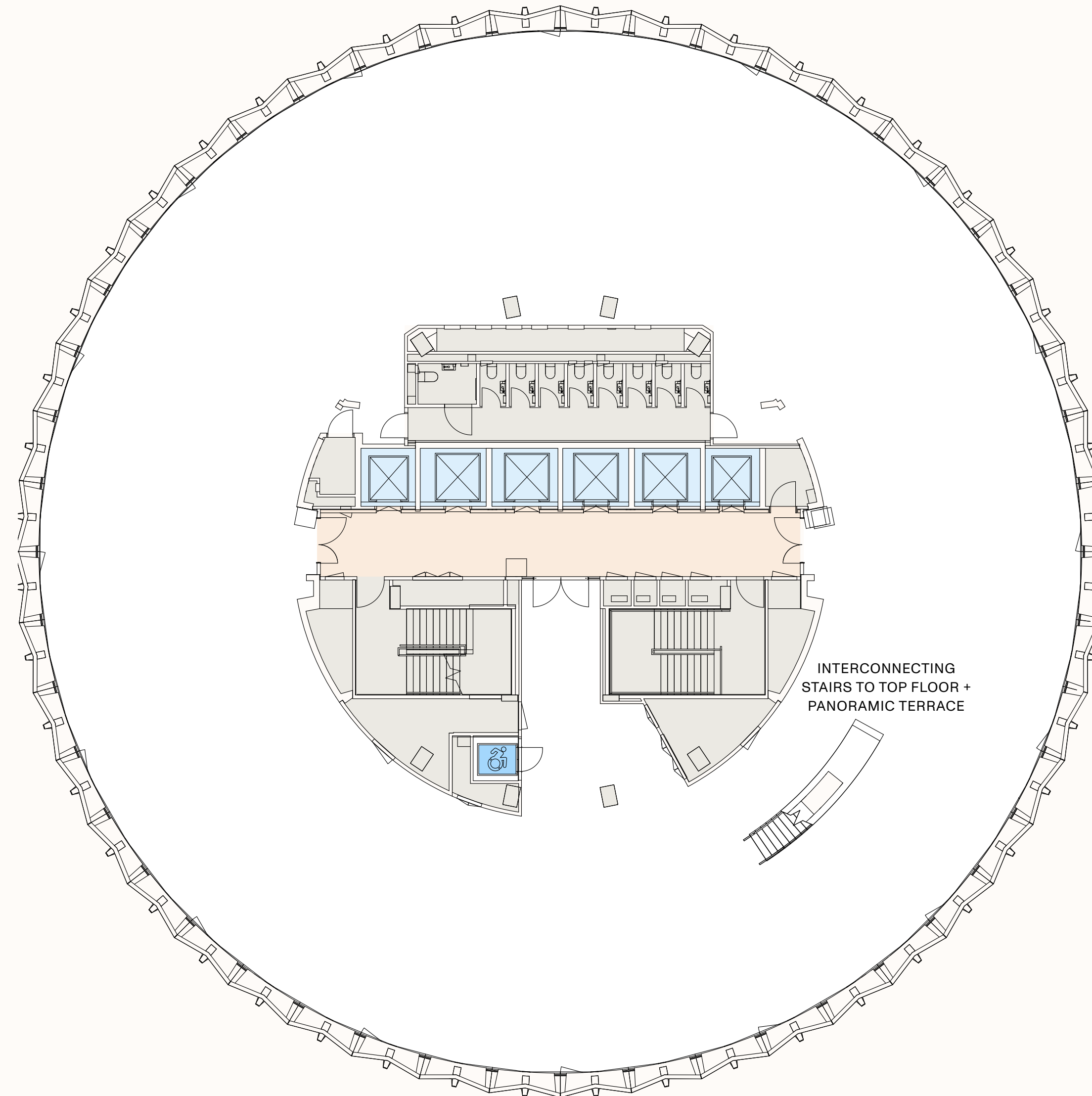

LEVEL 16

THE TOWER ●

WORKSPACE

10,370 sq ft



-  LIFTS
-  LIFT (ACCESSIBLE)
-  WORKSPACE
-  LIFT LOBBY
-  CORE

 NORTH

LEVEL 17

THE TOWER ●

WORKSPACE TERRACE

4,830 sq ft 3,659 sq ft

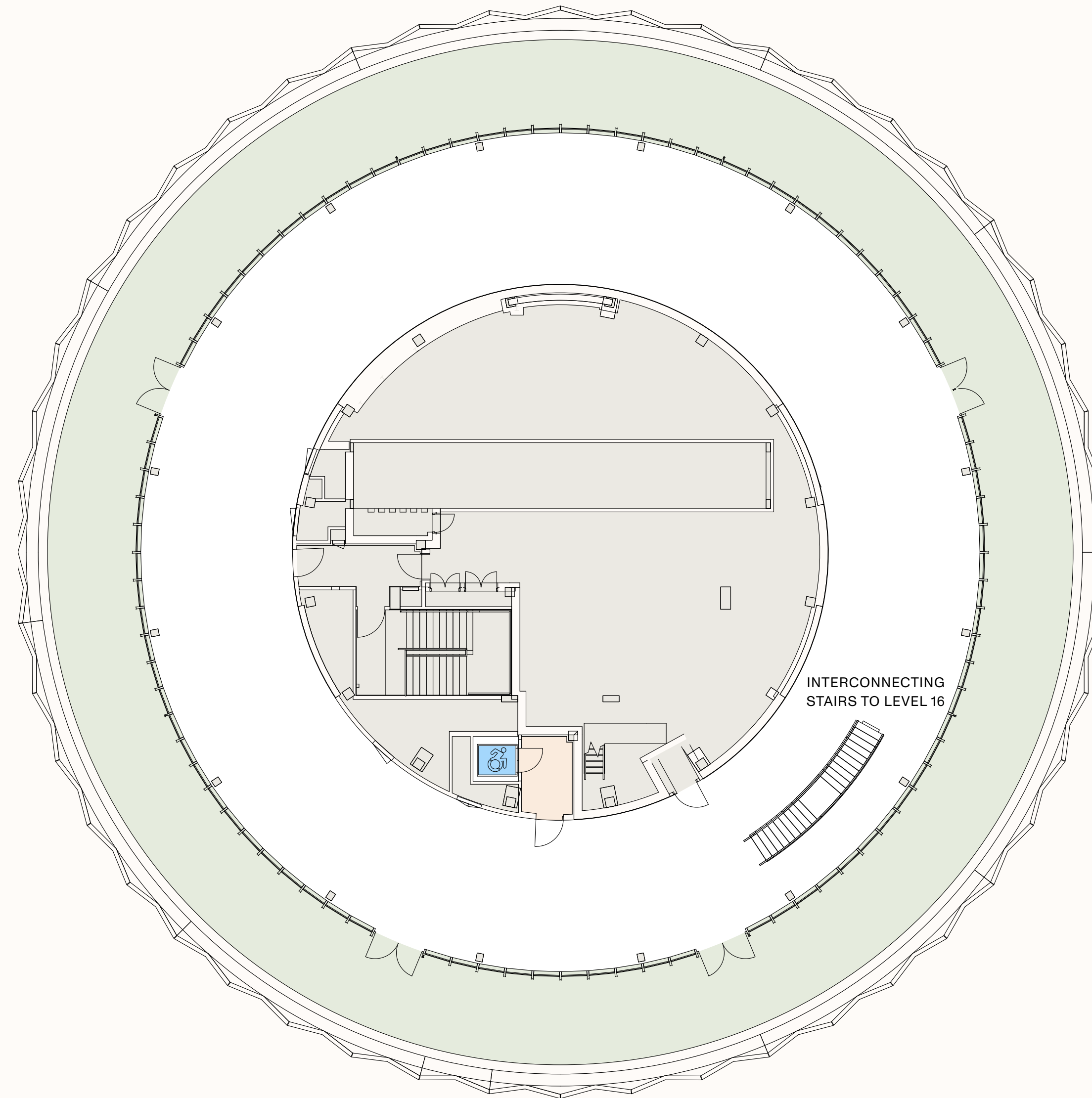

- TERRACE
- LIFT (ACCESSIBLE)
- WORKSPACE
- LIFT LOBBY
- CORE

↗ NORTH

LOWER GROUND 1









HYBRID 

MULTI-FUNCTION SPACE

2,835 sq ft

CYCLE

2,873 sq ft

-  CYCLE PARK FOR 550 BIKES
-  MULTI-FAITH / QUIET ROOM
-  SPACE STUDIOS
-  VOID/OPEN SPACE - DOUBLE-HEIGHT
-  SHOWERS AND CHANGING ROOMS
-  LIFT LOBBY
-  LIFTS
-  CORE

 NORTH

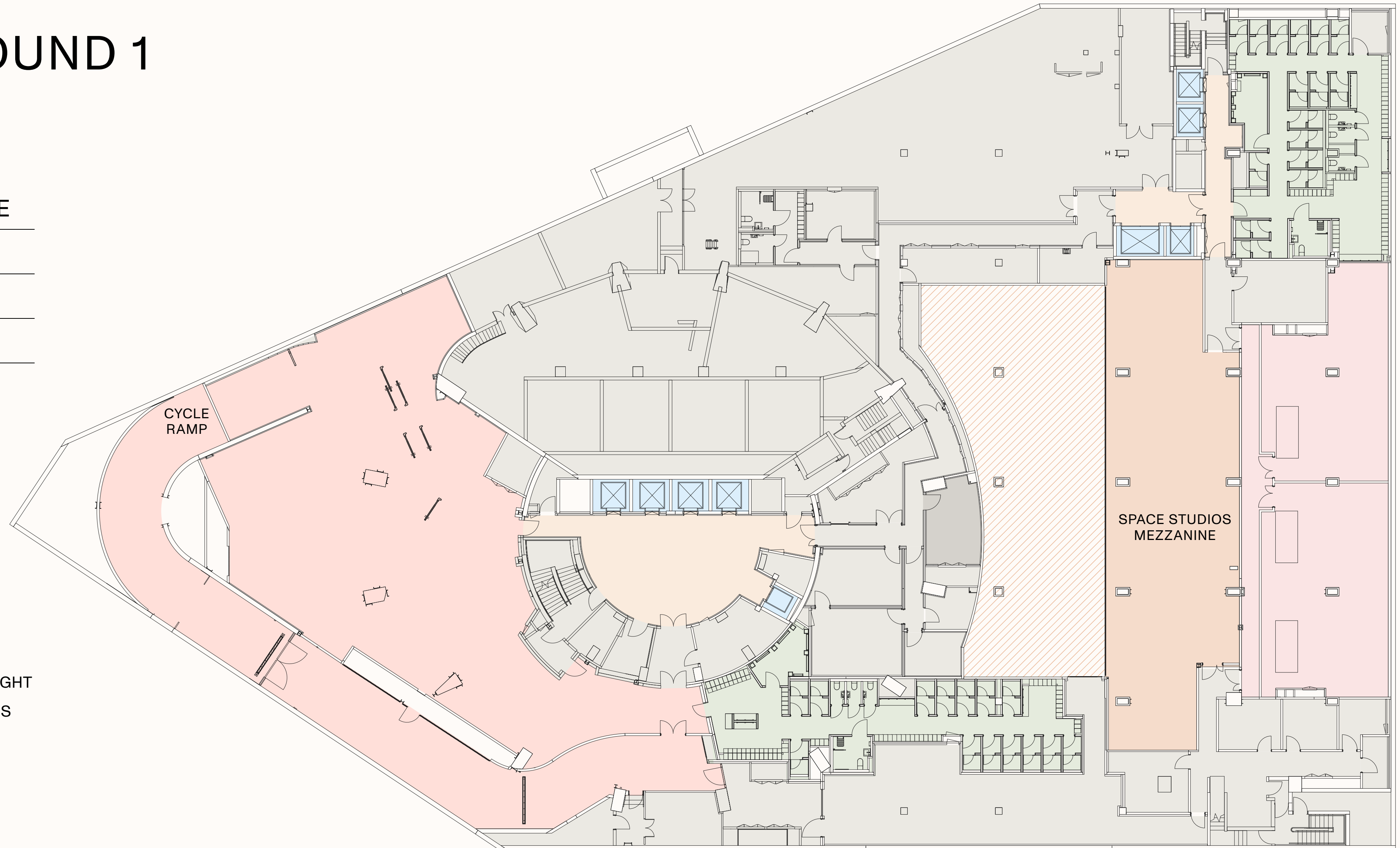







LOWER GROUND 2

HYBRID 

MULTI-FUNCTION SPACE

13,675 sq ft

-  SPACE STUDIOS
-  SHOWERS AND CHANGING ROOMS
-  LIFT LOBBY
-  LIFTS
-  CORE

 NORTH

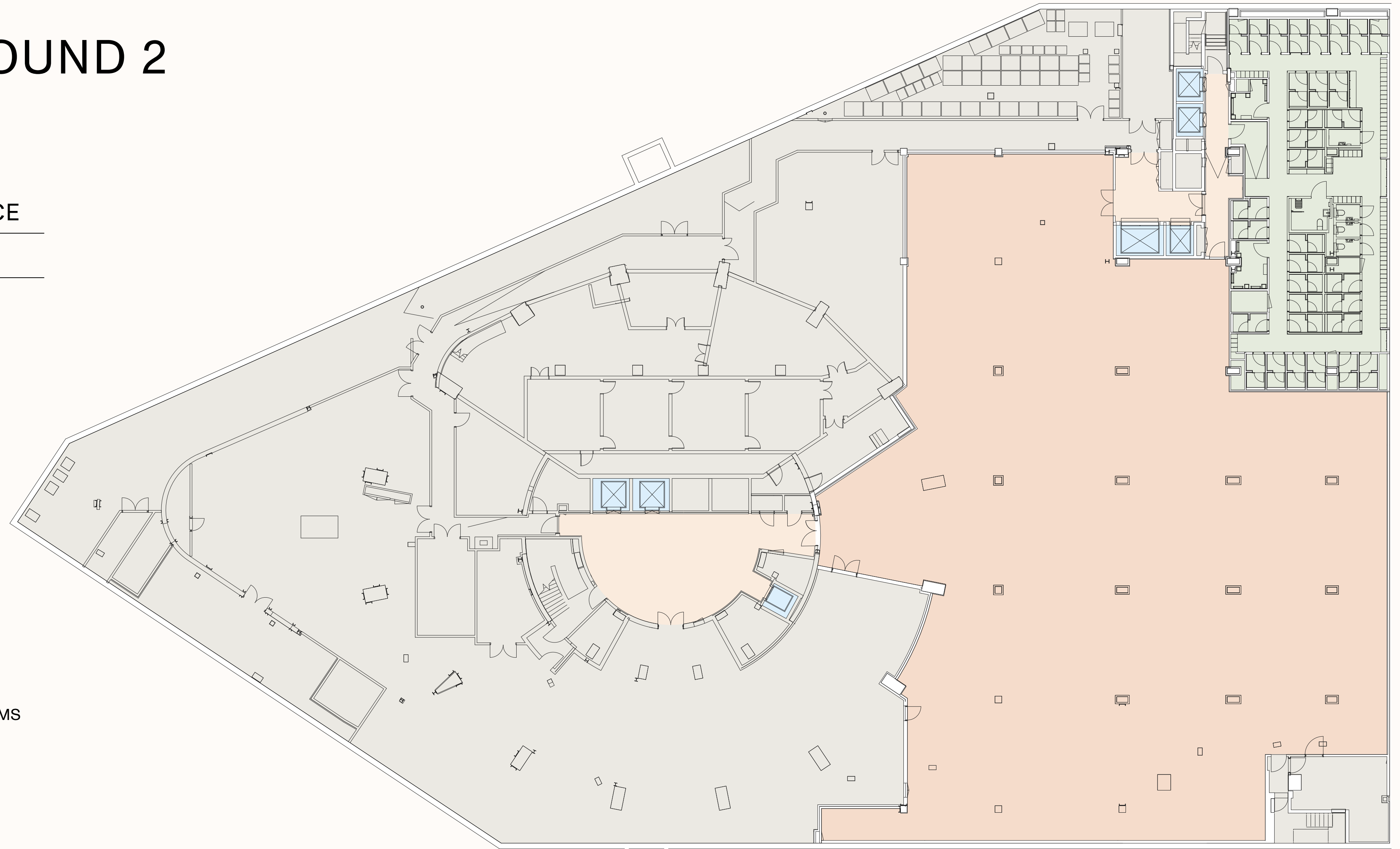

THE TOWER ●

CIRCULAR FLOOR BENEFITS

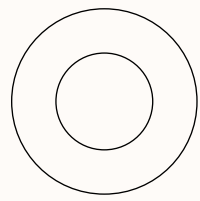

360° DAYLIGHT IN

Floor-to-ceiling windows provide a workspace flooded with natural light throughout the day.



360° VIEWS IN AND OUT

The floor-to-ceiling windows and Space House's central location in a conservation area, combine to offer spectacular, uninterrupted views of London from level 10 upwards. You can experience the whole of London's skyline, taking time out to calm the mind and recharge throughout the day.

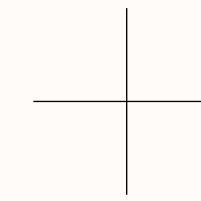
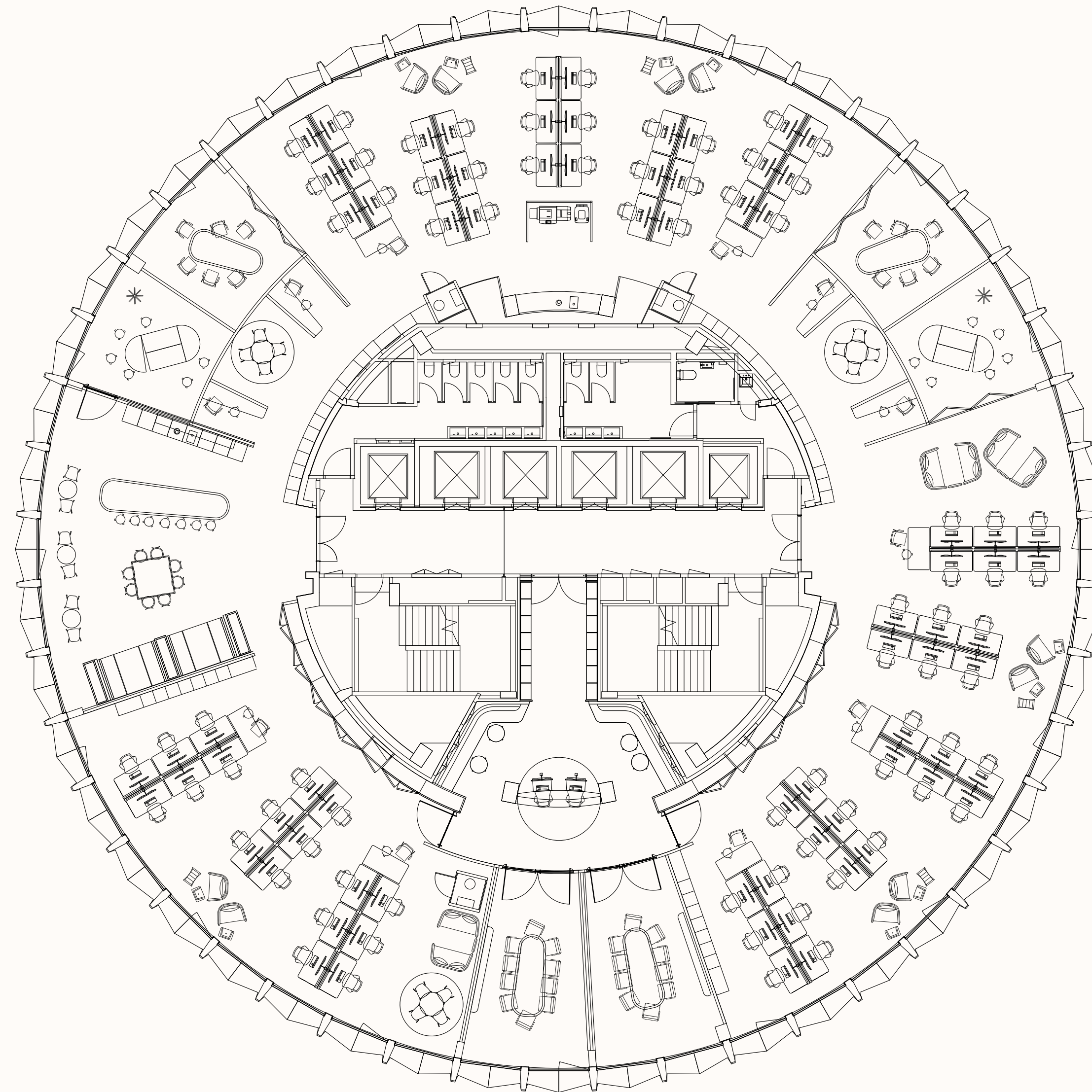

EQUALLY DIVISIBLE

A symmetrical floorplate enables simple and straightforward space planning. Three entrances off the core also make future subdivision easy, should business needs or cycles change.

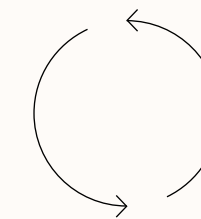

CONNECTED FLOW

A floor plate with no hard corners, columns and unusable areas encourages natural and unrestricted fluid movement of ideas, people and groups.

WORK FLOOR

THE TOWER ●

WORKSPACE

10,270 sq ft

Activity based working:
shared workspace with a
variety of worksettings and
no assigned desks.

MEETING ROOMS

| | |
|-----------|---|
| 10 Person | 2 |
| 6 Person | 4 |
| 4 Person | 2 |

SEAT SUMMARY

| | |
|---------------------|----|
| Open Desk Seats | 78 |
| Alternative Seats | 42 |
| Meeting Seats | 52 |
| Meeting Rooms | 8 |
| Kitchen / Hub Seats | 29 |

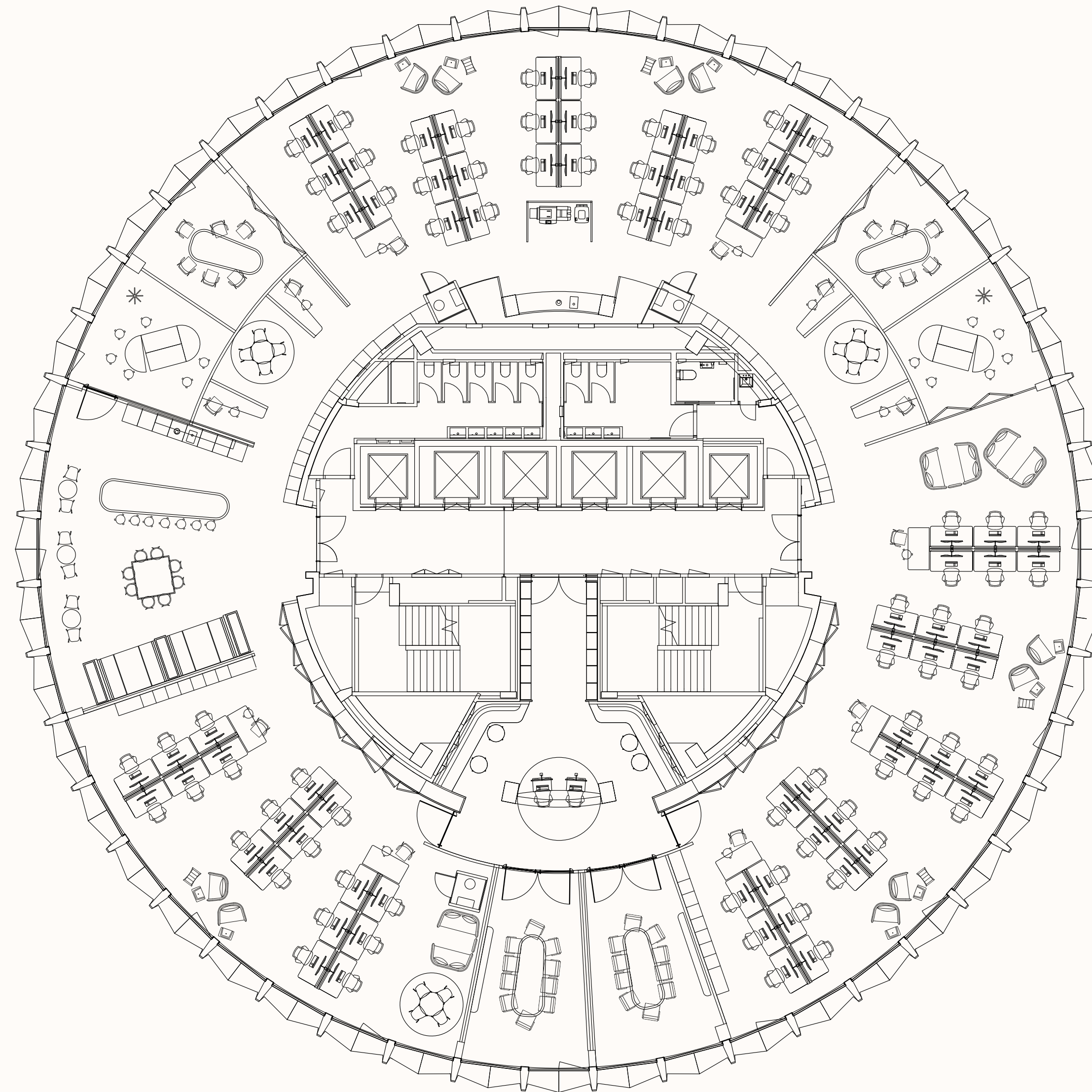
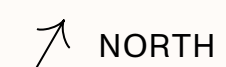

HEADCOUNT

217p @ 3 days per week in the office

130p @ 5 days per week in the office

The floorplate has a max occupancy of 119p
based on a 1:8 fire capacity density.

CLIENT FLOOR

THE TOWER ●

WORKSPACE

10,270 sq ft

Spaces include concierge, meeting areas, flexible spaces, business lounge, support spaces and client entertaining areas.

MEETING ROOMS

| | |
|-----------|---|
| 16 Person | 1 |
| 12 Person | 1 |
| 10 Person | 2 |
| 6 Person | 4 |
| 4 Person | 1 |

SEAT SUMMARY

| | |
|-------------------|-----|
| Meeting Seats | 128 |
| Alternative Seats | 88 |

↗ NORTH

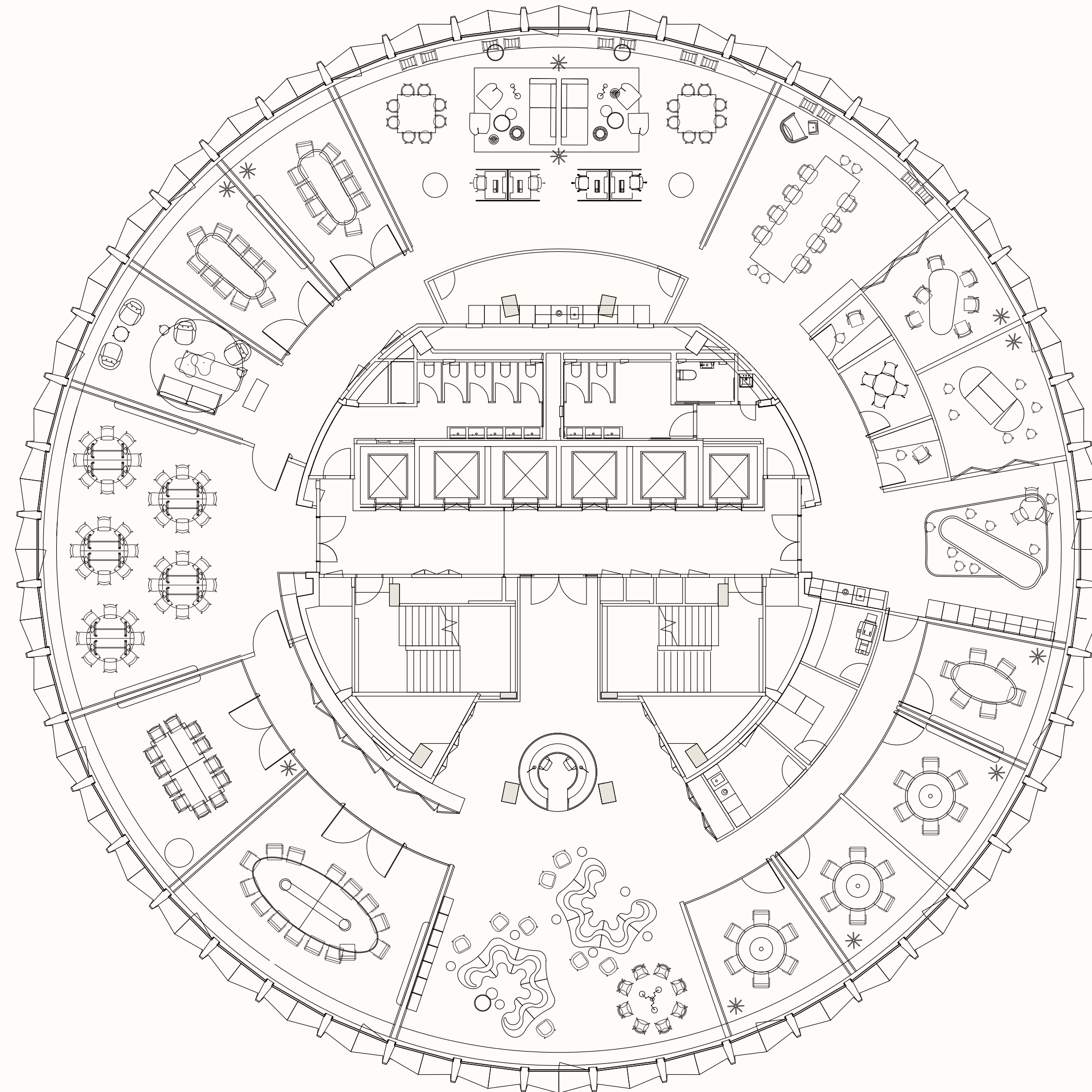

The floorplate has a max occupancy of 119p based on a 1:8 fire capacity density.

SMART BUILDING

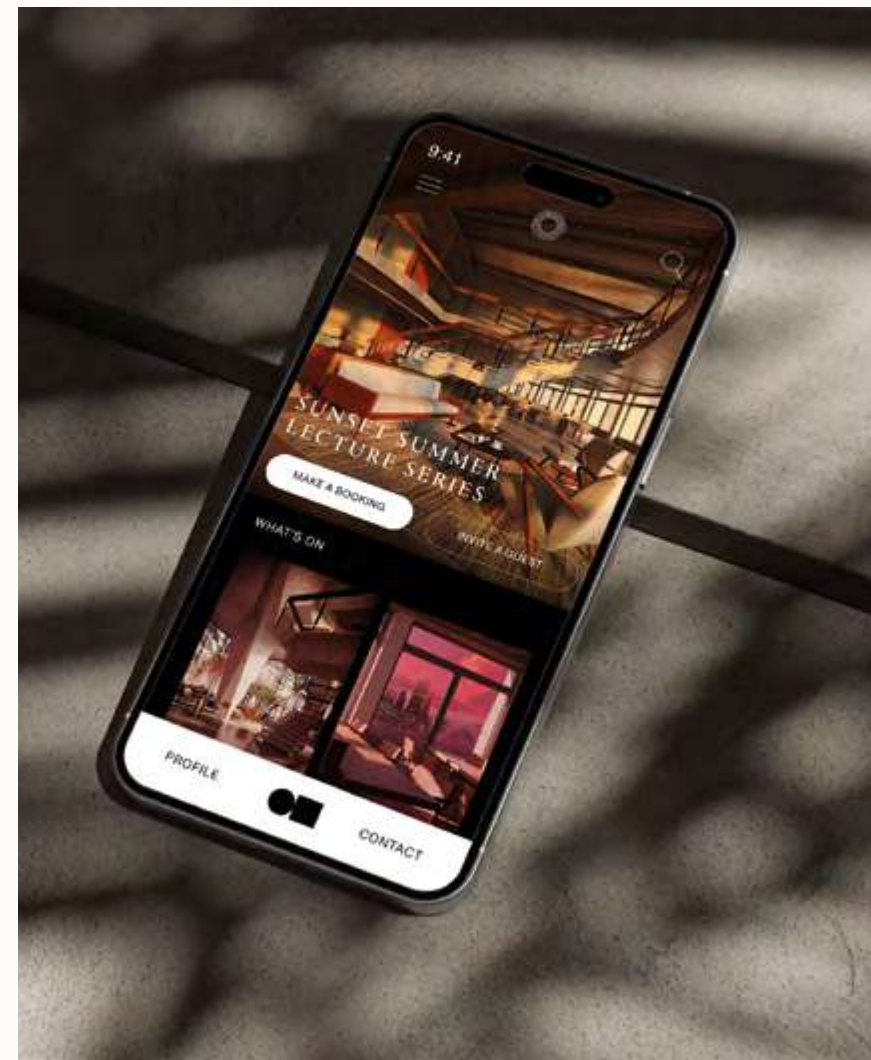

A smartphone app aids frictionless and secure movement throughout the building. There's an enhanced DAS system ensuring connection to high-speed fibre broadband and technology enhances the environment, both

internally and beyond. Smart lighting responds and adjusts to external ambient levels, CO2 and humidity levels are monitored and controlled, while thermal loading cools the building to reduce energy consumption.



A SUSTAINABILITY EXEMPLAR



NABERS 4.5*

Energy reduction and efficiency plays an essential role in our global transition to a decarbonised future. Space House's 4.5* rating is testament to the innovative technology and sustainability features – remarkable for a Grade II listed building.

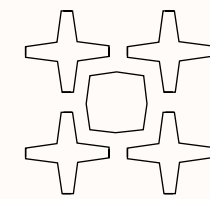

A BUILDING THAT BREATHES

Space House has automated opening windows which allow cold air into the building overnight to cool the internal concrete structure of the building and reduce the need for additional air conditioning and energy use the following day.

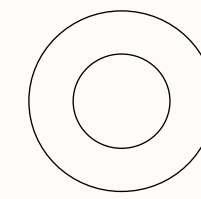

DAYLIGHT HARVESTING TECHNOLOGY

Daylight-activated sensors monitor natural light and adjust the internal levels to minimise unnecessary energy consumption.

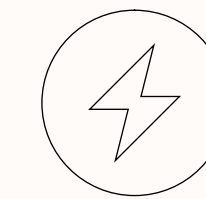

NET ZERO CARBON IN OPERATION

Designed to minimise its operational carbon footprint and reduce occupier costs. The fully electric smart technology monitors energy consumption, water and air quality in public areas and enables occupiers to add sensors to their demise for a holistic picture of energy consumption.

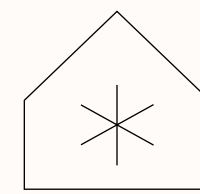

EPC A

The modernisation of Space House has preserved the building's heritage features whilst ensuring it is fit for the future. The building's EPC A rating far exceeds the anticipated 2027 and 2030 Minimum Energy Efficiency Standards (MEES) of EPC C and EPC B respectively.

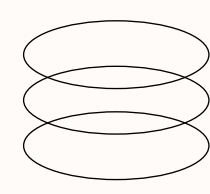

10,000 TONNES OF CARBON SAVED

The modernisation of this 1960s Grade II listed building focused on preservation and restoration rather than demolition. As a result, over 90% of the existing structure has been retained, saving 10,000 tonnes of carbon and waste materials.



BREEAM OUTSTANDING





Space House will be one of the first Grade II listed office buildings in London to achieve BREEAM 'outstanding' rating.

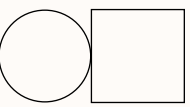
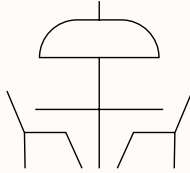
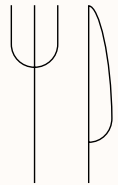
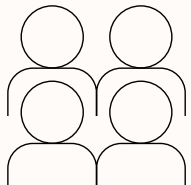
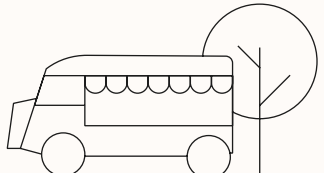
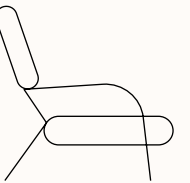
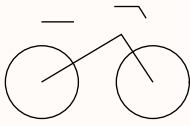

WIREDSCORE PLATINUM

Space House, originally built in 1968, is now one of the best-connected workspaces in the UK, with resilient dual power and data supply and an integrated full fibre backbone.

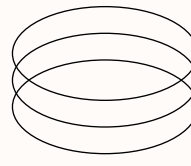
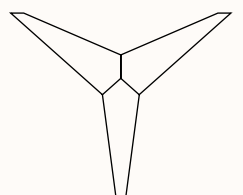
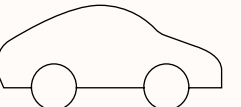
BUILT FOR THE FUTURE

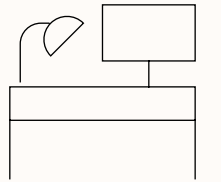
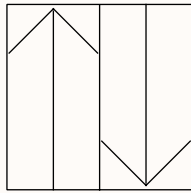
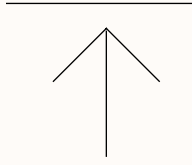
| | | | | |
|---|---|---|---|---|
|  |  |  |  |  |
| 230,100 SQ FT OF WORKSPACE | THE CLUBHOUSE AND TERRACE | FILLING STATION RESTAURANT | SPACE STUDIOS EVENT SPACE | PUBLIC PIAZZA |
|  |  |  |  |  |
| THE LOUNGE | 550 CYCLE SPACES & 65 SHOWERS | 360° ROOFTOP TERRACE | SMART BUILDING | EXPOSED ARCHITECTURE |
|  |  |  |  |  |
| 4 PARKING SPACES WITH E-CHARGING | FITWELL 2-STAR CERTIFICATION | WORKSPACE OCCUPANCY 1:8 | NEW HIGH SPEED LIFTS | EXPOSED CEILINGS |



THE HEART OF



Covent Garden is the home of London's culture, creativity and innovation scene. An unparalleled location with an incredible network of multi-national businesses, global brands, tech innovators and two highly respected universities in the UK.

THE CAPITAL



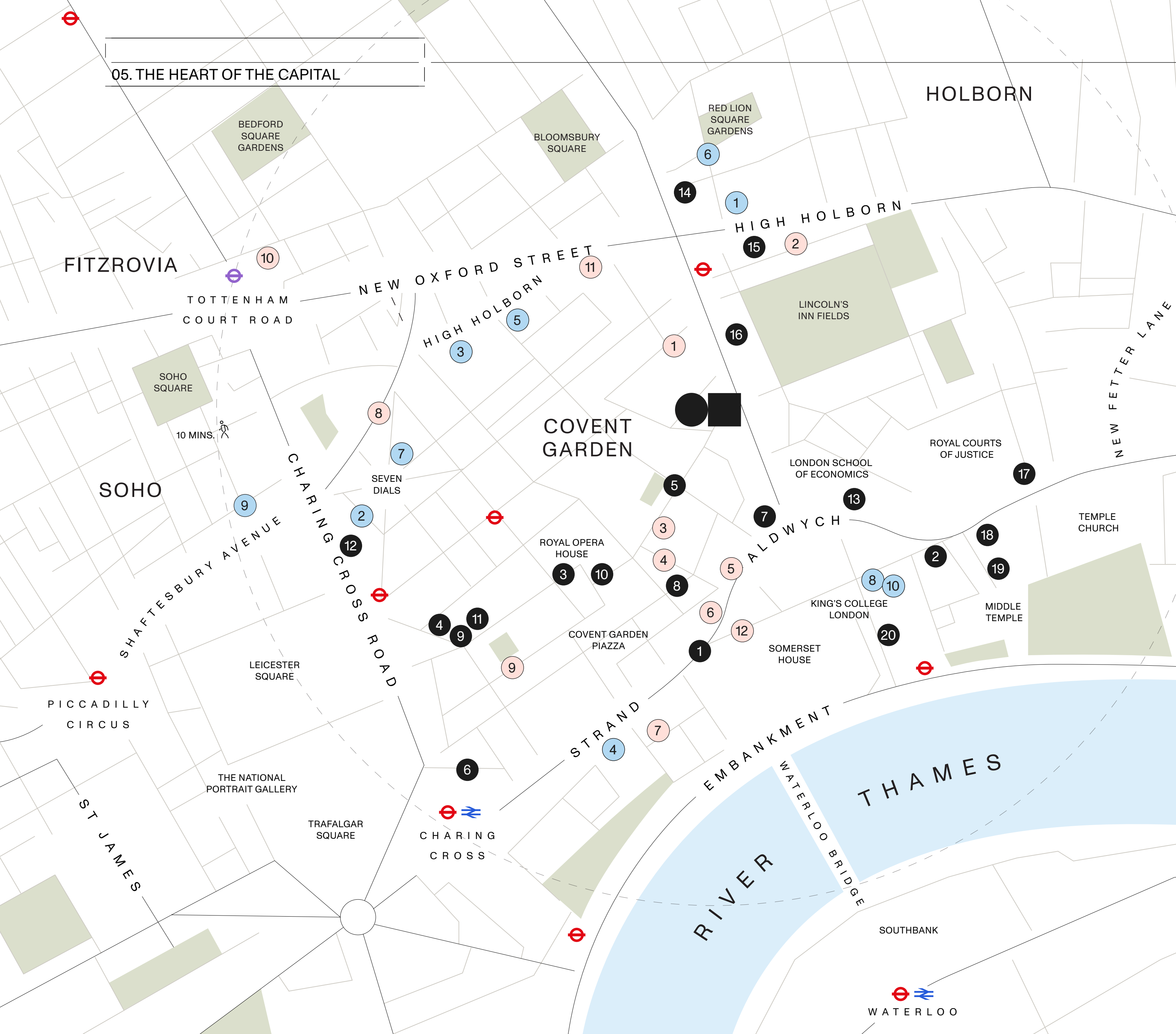

BEYOND SPACE HOUSE

RESTAURANTS

- 1 Frog by Adam Handling
- 2 Ikoyi
- 3 Sushisamba
- 4 La Goccia
- 5 Margot
- 6 Barrafina
- 7 The Delaunay
- 8 Cafe Murano
- 9 The Petersham
- 10 Balthazar
- 11 Clos Maggiore
- 12 The Ivy
- 13 Roka
- 14 L'oscar Restaurant
- 15 Holborn Dining Room
- 16 42 Holborn
- 17 Brasserie Blanc
- 18 The George
- 19 The Cheshire Cheese
- 20 Toklas

HOTELS

- 1 Middle Eight
- 2 Rosewood London
- 3 Fielding Hotel
- 4 Nomad London
- 5 The Waldorf
- 6 One Aldwych
- 7 The Savoy
- 8 Covent Garden Hotel
- 9 Henrietta Hotel
- 10 The Bloomsbury
- 11 The Hoxton Holborn
- 12 ME London

HEALTH + FITNESS

- 1 Gymbox
- 2 Digma Fitness
- 3 Aveda Lifestyle
- 4 Virgin Active
- 5 1Rebel
- 6 Boom Cycle
- 7 Caudalie Boutique Spa
- 8 180 House
- 9 Soho House
- 10 180 Studios

IN ESTEEMED COMPANY

Paul Smith

Ascential 

Mishcon de Reya

CONDÉ NAST

MARATHON
ASSET MANAGEMENT

Charlotte Tilbury

McKinsey
& Company

 PELOTON

Google

Goldman
Sachs

DAZED

APOLLO

GSK

Coutts 

BAIN & COMPANY 

 Spotify

GOAT

CVC

LSE

DARKTRACE

Rothesay

NICHOLAS KIRKWOOD

pwc

 PATRIZIA

 Industrial
Light & Magic

Covent Garden is home to visionary companies and creative thinkers brilliantly shaping the world's future.



Covent Garden Market



Side Hustle



Somerset House

The area is also home to world-class culture. Somerset House, 180 Studios, the Royal Ballet, Royal Opera and over 20 theatres call it home.

Royal Opera House



THE

NEIGHBOURHOOD



180 Studios

Seven Dials Market



Covent Garden is famous for some of London's best retail and dining. It's an eclectic mix of high-end restaurants and bars, luxury fashion and beauty brands, international retailers and market craft stalls.

NoMad



Paul Smith





1Rebel



Apple Store

Floral Street



London School of Economics

180 House



THE

NEIGHBOURHOOD



Lincoln's Inn Fields

King's College



Bush House

Located opposite Space House is the beautiful and tranquil Lincoln's Inn Fields, with tennis courts and a café. Bloomsbury Square, just a few minutes walk away, is one of London's first garden squares, dating back to the 1700s.

The area is also home to London's pre-eminent universities. King's College, with a distinguished reputation in humanities, law and the sciences, and the London School of Economics and Political Science (LSE), the leading social science institution in the world.

LONDON

CONNECTED

- BAKERLOO
- CENTRAL
- CIRCLE
- DISTRICT
- DLR
- ELIZABETH
- HAMMERSMITH + CITY
- JUBILEE
- METROPOLITAN
- NORTHERN
- PICCADILLY
- VICTORIA
- WATERLOO + CITY

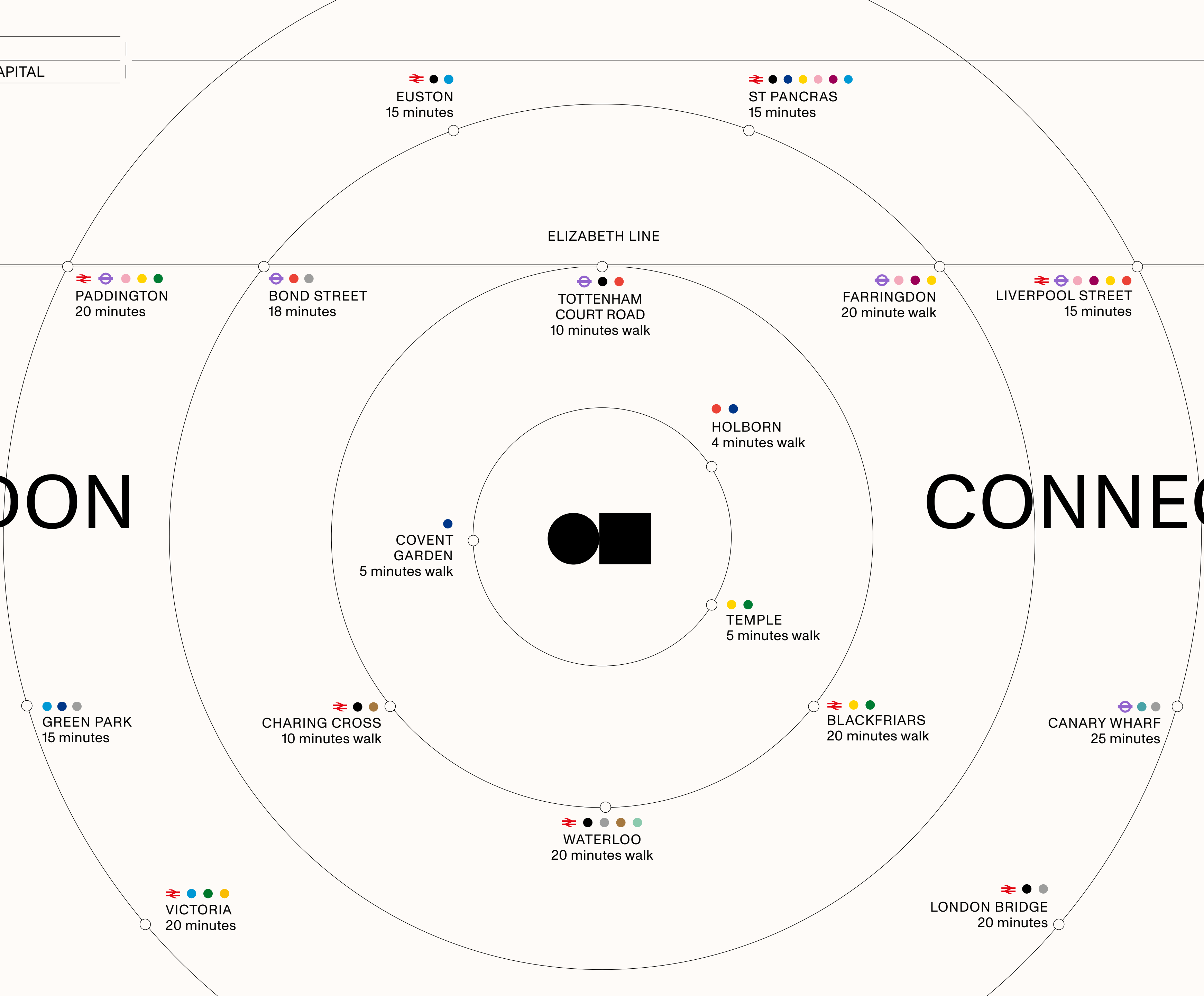

EUSTON
15 minutes

ST PANCRAS
15 minutes

PADDINGTON
20 minutes

BOND STREET
18 minutes

TOTTENHAM COURT ROAD
10 minutes walk

FARRINGTON
20 minute walk

LIVERPOOL STREET
15 minutes

HOLBORN
4 minutes walk

COVENT GARDEN
5 minutes walk

TEMPLE
5 minutes walk

CHARING CROSS
10 minutes walk

BLACKFRIARS
20 minutes walk

CANARY WHARF
25 minutes

WATERLOO
20 minutes walk

LONDON BRIDGE
20 minutes

GREEN PARK
15 minutes

VICTORIA
20 minutes

✈️
HEATHROW
40 minutes

GATWICK
40 minutes

CITY
41 minutes

THE STORY OF

SPACE HOUSE



Designed by Seifert & Partners for developer Harry Hyams during an era of immense change and progress in the sixties, Space House stands as one of London's most important architectural icons. The building was awarded grade II listed status in 2015.

Seaforth and QuadReal purchased the site in 2018 with a clear vision to undertake a remarkable restoration and modernisation programme.

THE RESULT, 255,000 SQ FT OF INTELLIGENT, ADAPTABLE, SUSTAINABLE, AND CHARACTERFUL WORK AND LIFESTYLE SPACES THAT REDEFINE OUR UNDERSTANDING OF MODERN WAYS OF WORKING.



1964 ————— 1968

A TIME OF CULTURAL, ARTISTIC AND TECHNOLOGICAL INNOVATION



Clock-wise from top-right:
Conceptual artwork of the original building; a historic
close-up of the building's sculptural form; interior architectural
details of original building (bottom left and centre).

Space House was imagined and created in the mid-century era when artistic abstraction influenced architectural design as a reaction to the linear precision of early Modernist buildings. Brutalist projects valued human relationships and interaction above all else, with the ambition of making people's lives better through architecture.

It was the golden age of architecture in the round. Richard Foster's Round House in Connecticut, Wolfgang Ewerth's Villa in Casablanca and the propeller-shaped concrete roof of John Lautner's Elrod House in Palm Springs were just some of the outstanding curved buildings of the 1960s.

Closer to home, James A. Roberts created the Rotunda building at the Bull Ring in Birmingham, while architects Richard Seifert and George Marsh worked with developer Harry Hyams and engineers

Pell Frischmann to design and build London's Centre Point and Space House, which became Seifert & Partners' most expressive, playful project, echoing the artistic trends of the time and adding an injection of space-age futurism.

George Marsh, the architect in charge of the project, imbued Space House with his signature eye-catching avant-garde design, quickly establishing it as a new London landmark as well as a symbol of 1960s dynamism, its circular form standing boldly alongside its more traditional, linear neighbours. Huge sculpted cruciforms defined the building's striking exterior and provided its main structure, enabling the interior workspaces to be completely column-free. Each 2.5-tonne cross was made from crushed capstone and white concrete and cast off-site, reducing the need for scaffolding during construction.

'BUILT BY THE MOST SUCCESSFUL DEVELOPER-ARCHITECT PARTNERSHIP OF THE DAY, ITS ASSERTIVE STYLING REFLECTING THE CONFIDENCE AND DYNAMISM ASSOCIATED WITH THE PERIOD.'

HISTORIC ENGLAND





2018 ——— 2024 BREATHING NEW LIFE INTO AN HISTORIC BUILDING

Seaforth and QuadReal acquired Space House in 2018, three years after it was designated a grade II listed building. Their ambition: to push the boundaries of responsible redevelopment through an authentic, considered approach to revive a sixty-year-old Brutalist icon, helping to protect the future of London's historic architecture, in parallel with delivering a desirable, high-performance workspace fit for the future.

SPACE HOUSE

Built between 1964 and 1968,
Grade II listed on Jan. 26, 2015

Designed by Richard Seifert &
Partners (partner-in-charge
George Marsh) for Harry Hyams

Reasons for grade II listed
designation:

ARCHITECTURAL INTEREST

As one of London's best speculative
office buildings, whose arresting
yet subtly-handled exteriors reflect
many of the 'Pop' themes at play
in the contemporary Centre Point
development.

TECHNICAL INTEREST

For the innovative use of a
precast concrete grid, a form
of partial prefabrication that
allowed for rapid construction
without the use of scaffolding, as
well as for striking visual effects.

HISTORIC INTEREST

As an icon of the 1960s commercial
property boom, built by the most
successful developer-architect
partnership of the day, its assertive
styling reflecting the confidence
and dynamism associated with
the period.

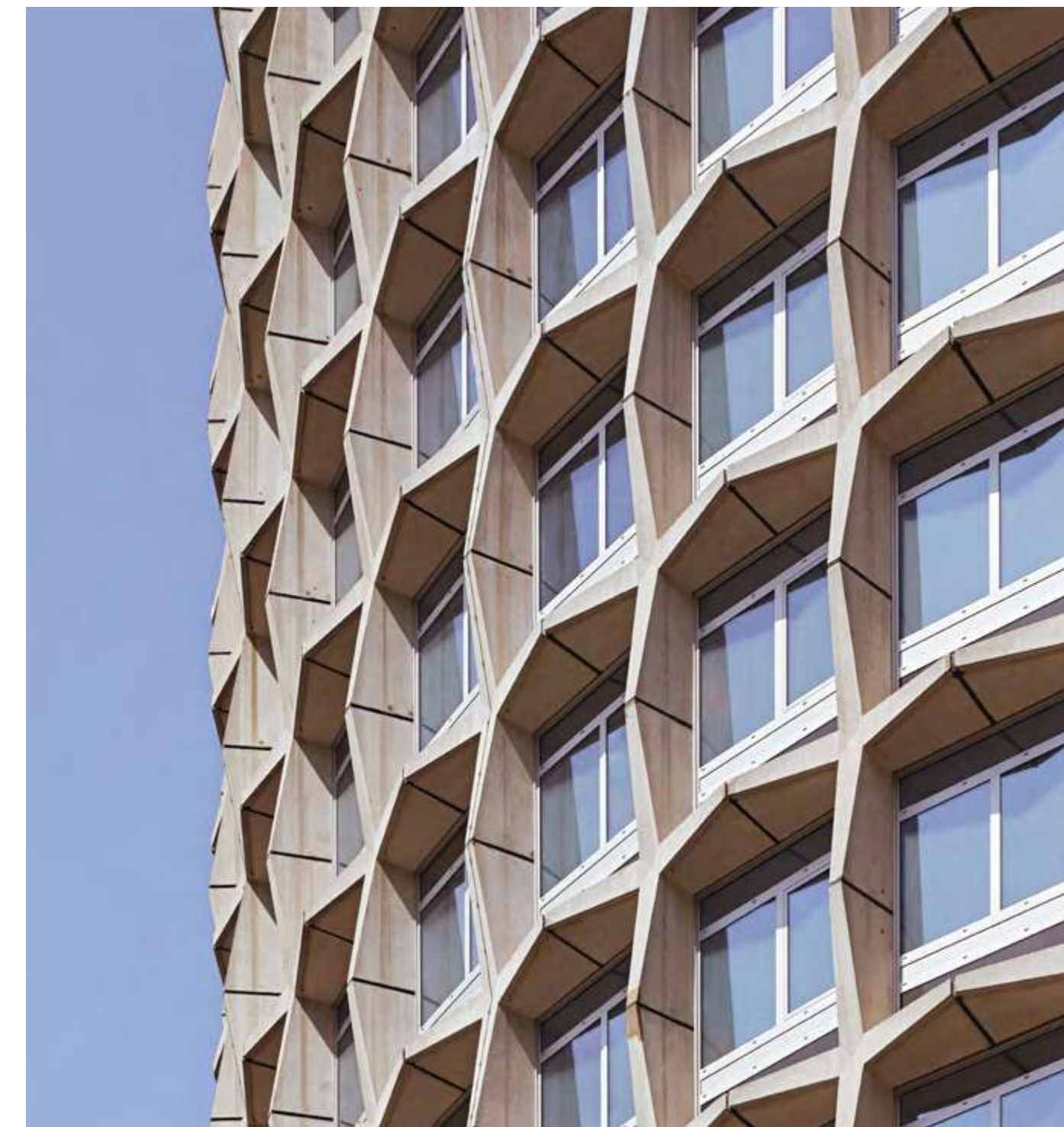

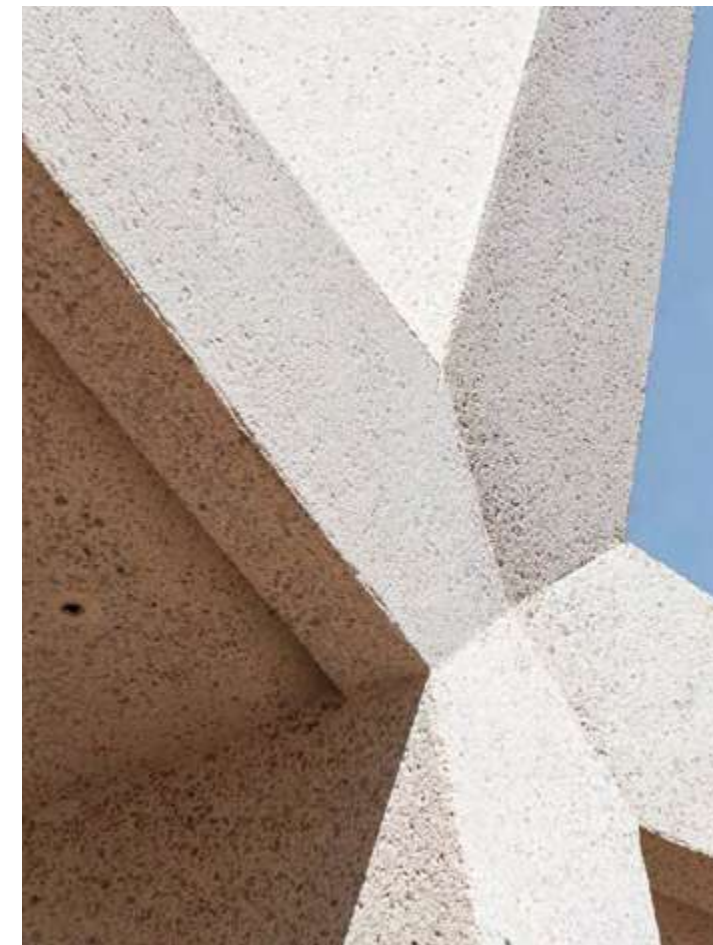
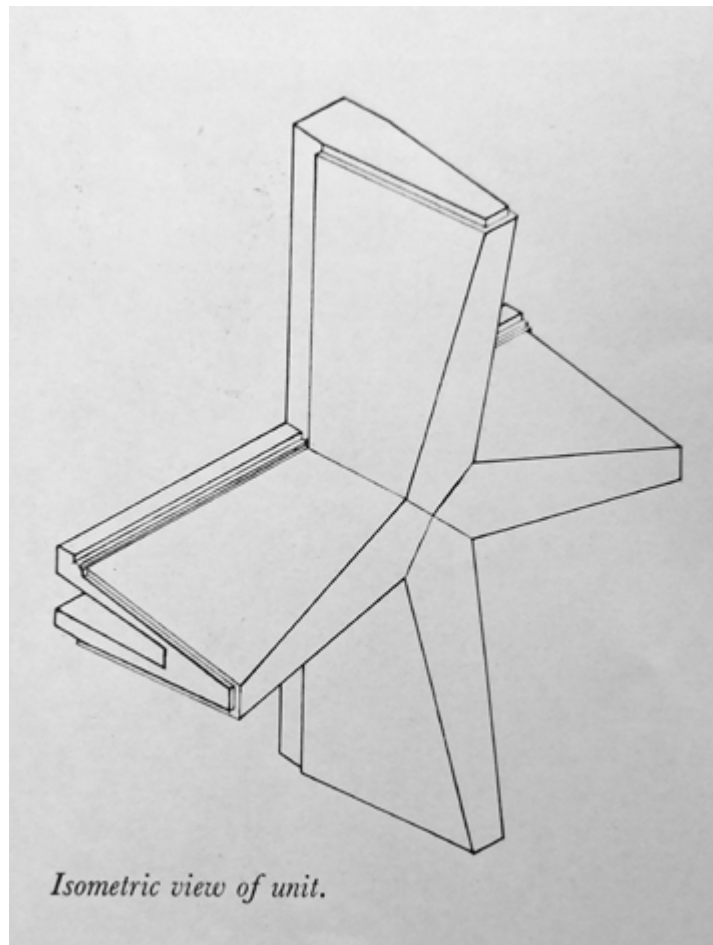

From left to right: Isometric illustration of architectural cruciform, the same structure used during the building's original construction in the 1960s. One of the replica cruciforms created for the level 17 extension.

The building's robust structure made it suitable for retrofit, the inherent strength of the existing frame – a pioneering hybrid of in-situ and precast concrete – required little additional strengthening. Unlike the structure, upgrading the tower's sliding windows to an energy-efficient automated system, however, posed a significant challenge. Each of the original windows had been made individually, resulting in differences of 20–30mm between each pane. By 3D-scanning every single opening on the tower, over 100 different window sizes emerged.

RAISING THE ROOF

Space House has grown from its original incarnation with two new storeys and a terrace added to the tower, an extra one to the block, a double-height event space carved from the vast subterranean

basement car park, and a restaurant aptly named 'The Filling Station' replacing the site's former petrol station on ground level.

The rooftop extension on the tower was a major feat of precision engineering. A completely new layer of 2.5-tonne load-bearing cruciforms was needed to support the new floors. In all, 48 exact reproductions of the original cruciform units were designed and manufactured off-site using data from archive drawings, 3D scans and analysis of existing panels. The top of the existing building was formed of a ring of T-shaped units; a heritage requirement was that these original T-units were retained and reinstalled on the new, higher level. In what may be a reuse first, the T-shapes were cleaned, repaired, and reinstalled as the rejuvenated building's crown.



CARBON SAVINGS

Space House's BREEAM Outstanding rating is one of the first for a listed building in London.

Services Engineers, Atelier Ten predicts a 46% reduction in operational carbon in the tower extension and 70% across the rest of the project. The modernisation of the 1960s icon prioritised preservation and restoration, successfully retaining over 90% of the existing structure. Structural Engineers, Pell Frischmann, calculated that this is equivalent to approximately 10,000 tonnes of embodied carbon, comfortably below the LETI 2030 target.

SUSTAINABILITY FEATURES

Openable windows are part of a natural cooling system that was built into the original structure, with open floorplates facilitating cross-ventilation. In tandem with energy-efficient air-source and water-source heat pumps, the workspaces will benefit from natural cooling for 30% of the year; in the warmer months, the building can automatically open the windows by up to about 100mm at night, allowing it to breathe, to cool down the internal structure and thermally load it for the next day.

This is just one of several examples of the building's existing features blending seamlessly with modern technology to reduce energy consumption, and further enhancing its net zero carbon operational status.



'SPACE HOUSE IS ONE OF THE MOST IMPORTANT REDEVELOPMENT PROJECTS OF OUR TIME.'

HISTORIC ENGLAND

LOOKING TO THE FUTURE

From left to right:
Exterior render of the restored building,
interior renders showing how the radial
floorplates meet the external glazing.

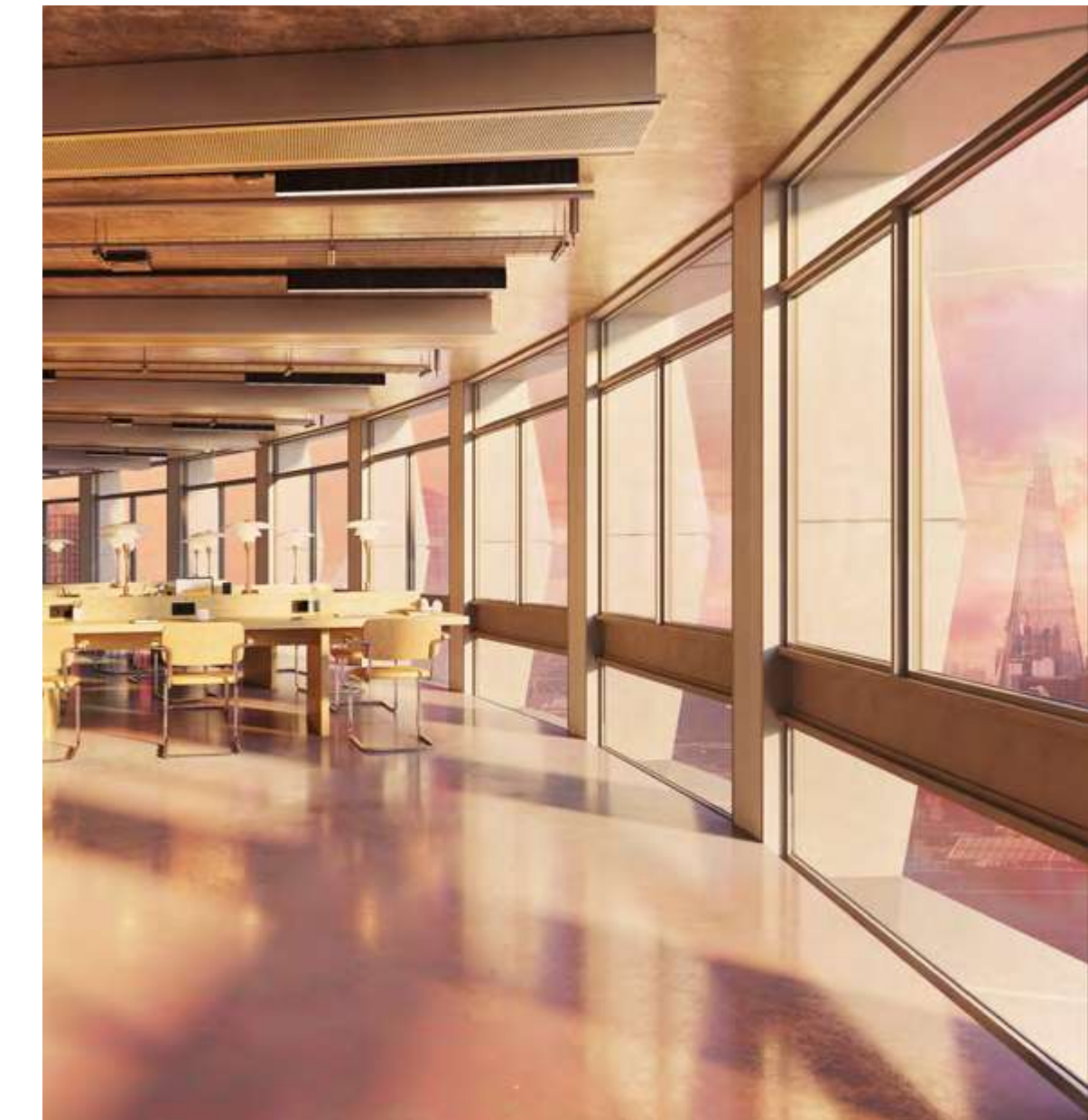

SPACE HOUSE RETAINS THE MOOD AND SPIRIT OF THE ERA: A REVOLUTIONARY, PROGRESSIVE OPTIMISM WHICH IS AS RELEVANT TO TODAY'S GENERATION AS IT WAS BACK IN THE MID-60S.

Space House has been updated for a digital, more carbon-conscious age. This project demonstrates how heritage buildings can be beautifully transformed into inspiring workspaces, filled with personality and character. It is a reflection of how historical elegance can be uplifted and repurposed as modern lifestyle and work spaces. With forethought and a perspective of innovation,

modern services and technology can seamlessly integrate with the most interesting architectural features. An enduring icon of Brutalist architecture, Space House has always drawn those who see the world differently. As striking today as it was upon its completion in 1968, Space House is designed for the movers and shakers, the progressive thinkers leading tomorrow.



Bleeding Heart Yard



DEVELOPER



SEAFORTH CREATES WORKSPACES THAT SEAMLESSLY INTEGRATE MODERN AESTHETICS, TECHNOLOGY AND AMENITIES WITH HISTORICAL CHARM.

Seaforth is passionate about restoring and extending buildings' lives, upcycling existing buildings, breathing new life into them while preserving their architectural heritage.

8 Bleeding Heart Yard has been honoured with multiple awards, including an NLA Award in the Workplace category as well as winning Silver at the BETTER FUTURE London Design Awards.



Chelsea Barracks
London SW1



Landmark Pinnacle
London E14



78 St James's Street
London SW1A

ARCHITECT
SQUIRE & PARTNERS

SQUIRE & PARTNERS IS AN INTERNATIONALLY RENOWNED ARCHITECTURE AND DESIGN PRACTICE WITH EXPERIENCE SPANNING FOUR DECADES.

The practice's approach responds to the unique heritage and context of each site to create timeless architecture rooted in its location. Embracing traditional and

emerging technologies in design and construction, the practice is renowned for delivering a rigorously detailed product.



STRUCTURAL ENGINEER
Pell Frischmann

Left: Zayed Centre,
London

Right: Singapore
Changi Airport

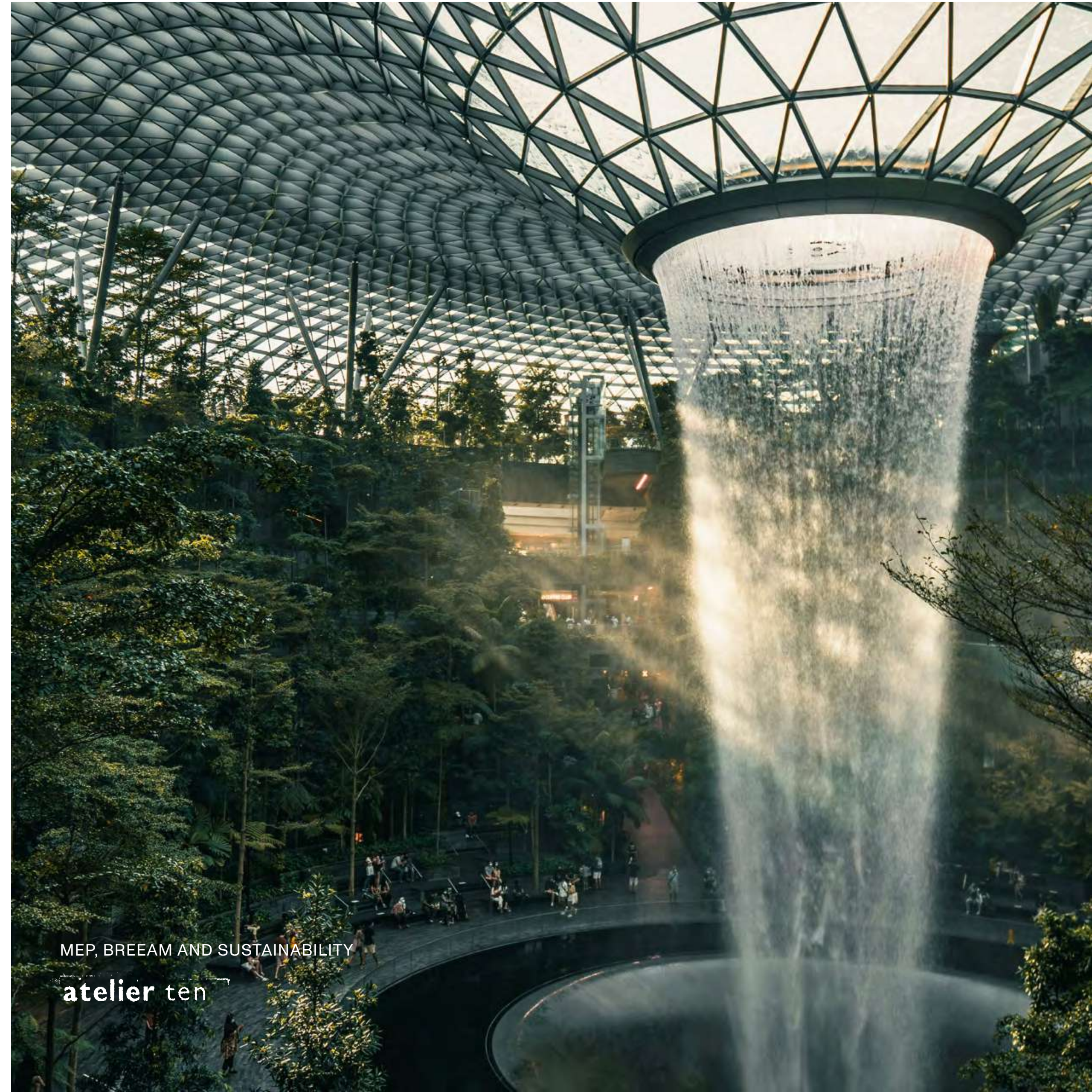

MEP, BREEAM AND SUSTAINABILITY

atelier ten

COST AND COMMERCIAL

GT GARDINER
& THEOBALD

LANDSCAPE DESIGNER

Gustafson
Porter +
Bowman

DEVELOPER

 QuadReal

DEVELOPMENT AND
PROJECT MANAGER

**AVISON
YOUNG**



INSTAGRAM @SPACEHOUSELONDON

LINKEDIN SPACE HOUSE LONDON

WEBSITE SPACEHOUSE.LONDON 1 KEMBLE STREET, LONDON, WC2

CBRE and Savills on their behalf and for the Vendors or Lessors of this property whose Agents they are, give notice that: 1. These particulars are set out as a general outline only for guidance to intending Purchasers or Lessees, and do not constitute any part of an offer or contract. 2. Details are given without any responsibility and any intending Purchasers, Lessees or Third Parties should not rely on them as statements or representations of fact, but must satisfy themselves by inspection or otherwise as to the correctness of each of them. 3. No person in the employment of CBRE and Savills has any authority to make any representation or warranty whatsoever in relation to this property. 4. Unless otherwise stated, all prices and rents are quoted exclusive of VAT. Copyright © Space House 2024. Summer 2024 edition.

Brochure designed and produced by SAENTYS +44 (0)20 7407 8717 info@saentys.com | saentys.com | 4386

A DEVELOPMENT BY



HUNTER BOOTH
+44 (0)7710 965 693
HUNTER.BOOTH@SAVILLS.COM

NICK PEARCE
+44 (0)7879 881 366
NICK.PEARCE@SAVILLS.COM

ANDREW WEDDERSPOON
+44 (0)7807 999 363
AWEDDERSPOON@SAVILLS.COM



MATT CHICKEN
+44 (0)7852 205 099
MATT.CHICKEN@CBRE.COM

ALEX KERR
+44 (0)7867 185 924
ALEX.KERR@CBRE.COM

DANA HENRY
+44 (0)7494 232 304
DANA.HENRY@CBRE.COM

GEORGINA WILLOUGHBY
+44 (0)7788 706 031
GEORGINA.WILLOUGHBY@CBRE.COM